

**DETAILED PROJECT REPORT  
ON**

**SOLAR – AERO GENERATOR HYBRID POWER SYSTEM  
(JORHAT TEA CLUSTER)**



**Bureau of Energy Efficiency**

*Prepared By*



*Reviewed By*



# **3 kW SOLAR – AERO GENERATOR HYBRID POWER SYSTEM**

**JORHAT TEA CLUSTER**

---

BEE, 2010

*Detailed Project Report on 3 kW Solar – Aero Generator  
Hybrid Power System,*

Jorhat Tea Cluster, Assam (India)

New Delhi: Bureau of Energy Efficiency;

Detail Project Report No.: **PCRA/JTC/ SAG/ \_\_\_\_\_**

---

**For more information**

Bureau of Energy Efficiency (BEE)  
(Ministry of Power, Government of India)  
4<sup>th</sup> Floor, Sewa Bhawan  
R. K. Puram, New Delhi – 110066

**Telephone** +91-11-26179699

**Fax** +91-11-26178352

**Websites:** [www.bee-india.nic.in](http://www.bee-india.nic.in)

**Email:** [jsood@beenet.in/](mailto:jsood@beenet.in)

[pktiwari@beenet.in](mailto:pktiwari@beenet.in)

## **Acknowledgement**

We are sincerely thankful to the Bureau of Energy Efficiency, Ministry of Power, for giving us the opportunity to implement the 'BEE SME project in "Jorhat Tea Cluster, Jorhat". We express our sincere gratitude to all concerned officials for their support and guidance during the conduct of this exercise.

Dr. Ajay Mathur, Director General, BEE

Smt. Abha Shukla, Secretary, BEE

Shri Jitendra Sood, Energy Economist, BEE

Shri Pawan Kumar Tiwari, Advisor (SME), BEE

Shri Rajeev Yadav, Project Economist, BEE

Petroleum Conservation Research Association (PCRA) is also thankful to various tea associations like ABITA (Assam Branch of Indian Tea Association), TAI (Tea Association of India), ATPA (Assam Tea Planters Association), NETA (North East Tea Association), etc., for their valuable inputs, co-operation, support and identification of the units for energy use and technology audit studies and facilitating the implementation of BEE SME program in Jorhat Tea Cluster.

We take this opportunity to express our appreciation for the excellent support provided by Local Service Providers, and Equipment Suppliers for their active involvement and their valuable inputs in making the program successful and in completion of the Detailed Project Report (DPR).

PCRA is also thankful to all the owners of the tea factories, plant in charges and all workers of the tea factories for their support during the energy use and technology audit studies and in implementation of the project objectives.

***Petroleum Conservation Research Association***

**Guwahati**

## Contents

List of Annexure	iv
List of Tables	iv
List of Figure	v
List of Abbreviation	vi
Executive summary	vii
About BEE'S SME program	x
<b>1 INTRODUCTION .....</b>	<b>1</b>
1.1 Brief about Jorhat Tea Cluster .....	1
1.2 Energy Performance in Existing Situation .....	3
1.2.1 Energy Consumption Profile .....	3
1.2.2 Average Production .....	4
1.2.3 Specific Fuel Consumption & Specific Electricity Consumption .....	4
1.3 Identification of Technology/ Equipment: .....	5
1.3.1 Present Withering Method: .....	5
1.3.2 Role of Withering in Tea Manufacturing Process .....	6
1.4 Baseline establishment: .....	6
1.4.1 Baseline from the Existing System.....	7
1.4.2 Design and Operation Parameters.....	8
1.4.3 Specific Electricity Consumption during Withering: .....	9
1.5 Barriers for Adoption of Solar – Aero Generator Hybrid Power System.....	9
1.5.1 Technological Barrier.....	9
1.5.2 Financial Barriers.....	10
1.5.3 Skilled Manpower .....	10
1.5.4 Barriers Specific towards adoption of this technology .....	11
<b>2 PROPOSED TECHNOLOGY FOR RENEWABLE POWER GENERATION .....</b>	<b>12</b>
2.1 Detailed description of the proposed system .....	12
2.1.1 Description of technology.....	12
2.1.2 Operation of the aero generator.....	12
2.1.3 Equipment specification.....	13
2.1.4 Suitability or integration with existing process.....	14

2.1.5	Superiority of solar – aero generator hybrid power system: .....	14
2.1.6	Availability of the technology:.....	15
2.1.7	Service Providers.....	15
2.1.8	Terms of sales .....	15
2.1.9	Process Down Time During Implementation: .....	15
2.2	Life Cycle Assessment: .....	15
<b>3</b>	<b>ECONOMIC BENEFITS DUE TO THE PROPOSED TECHNOLOGY .....</b>	<b>16</b>
3.1	Technical Benefits .....	16
3.1.1	Fuel Savings Per Year .....	16
3.1.2	Electrical Power Generation per year.....	16
3.2	Monetary Benefits.....	16
3.3	Social Benefits:.....	17
3.3.1	Improvement in Working Environment in the Tea Factory.....	17
3.3.2	Improvement in the Skill of the Worker .....	17
3.4	Environmental Benefits.....	17
3.4.1	Reduction in Effluent Gases .....	17
3.4.2	Reduction in GHG emission such as CO <sub>2</sub> , NO <sub>x</sub> , etc.....	17
<b>4</b>	<b>IMPLEMENTATION OF THE PROPOSED TECHNOLOGY.....</b>	<b>18</b>
4.1	Cost of Technology:.....	18
4.2	Arrangement of Fund.....	18
4.2.1	Financial Assistance .....	18
4.2.2	Entrepreneurs' Contribution .....	19
4.2.3	Loan Amount .....	19
4.2.4	Terms and Conditions of the Loan .....	19
4.3	Financial Indicators.....	19
4.4	Sensitivity analysis.....	20
4.5	Procurement and implementation schedule: .....	20

**List of Annexure**

Annexure 1: Process Flow Diagram.....21

Annexure 2: Energy audit data used for baseline establishment.....22

Annexure 3: Detailed technology assessment report .....23

Annexure 4: Specification of Aero Generator.....24

Annexure 5: Detailed Financial Calculation & Analysis for Financial Indicators.....25

Annexure 6: Procurement and implementation schedule .....29

Annexure 7: Details of Technology Service Provider .....30

Annexure 8: Quotations or Techno-commercial bids for new technology/equipment 31

Annexure 9: MNRE Subsidy Document .....34

**List of figures**

Figure1: Open Trough Withering .....5

Figure 2: Enclosed Trough Withering .....5

Figure 3: Hybrid power System ..... 12

**List of Tables**

Table1: Annual Energy Consumption of Tea factories using coal.....3

Table2: Annual Energy Consumption of Tea factories using Natural Gas.....3

Table3: Specific energy consumption of tea factories.....4

Table 4: Baseline Parameters .....6

Table 5: Average speed and corresponding Wind Power Density of the tea factories .....8

Table 6: Electrical Power Regeneration by the proposed technology ..... 16

Table 7: Monetary benefits from the proposed technology ..... 17

Table 8: Capital expenditure for the proposed technology ..... 18

Table 9: Financial indicators of proposed technology/equipment.....20

Table 10: Sensitivity Analysis .....20



## **List of Abbreviation**

BEE	Bureau of Energy Efficiency
MNRE	Ministry of New and Renewable Energy
MoMSME	Ministry of Micro Small and Medium Enterprises
MSME	Micro Small and Medium Enterprises
SIDBI	Small Industrial Development Bank of India
DPR	Detailed Project Report
GHG	Green House Gases
DSCR	Debt Service Coverage Ratio
NPV	Net Present Value
IRR	Internal Rate of Return
ROI	Return on Investment
FRP	Fiber Reinforced Plastic
SCUM	Standard Cubic Meter
MW	Mega Watt
MT	Metric Ton
kCal	Kilo – Calorie
kWh	Kilo Watt Hour
NG	Natural Gas

## EXECUTIVE SUMMARY

Petroleum Conservation Research Association (PCRA) is the executing BEE – SME program for Jorhat Tea Cluster, supported by Bureau of Energy Efficiency (BEE) with an overall objective of improving the energy efficiency in cluster units.

Jorhat cluster is one of the largest tea clusters in India; accordingly this cluster was chosen for energy efficiency improvements by implementing energy efficient measures/technologies, so as to facilitate maximum replication in other tea clusters in India. The main energy forms used in the cluster units are grid electricity, Natural gas, coal, and Diesel oil mainly to provide power during off – grid period.

The tea factories of Jorhat Cluster uses either Natural Gas or Coal as the source for thermal energy requirement, and for electrical energy requirement, grid power is used. In case of failure in the power supply from the grid, DG sets fuelled by diesel oil is used to meet the requirement of electrical energy in the tea factories.

During the audit period, it was found that the average speed of the waste air coming out of enclosed type of withering trough is 10.68 m/s. The waste air from the withering trough does not only have speed but also is dense, as it carries along with it the moisture of the tea leaves. The potentiality of the kinetic energy of this moisture laden waste air coming out of the withering trough is estimated as 2394 kWh/ m<sup>2</sup> per year per tea factory, which opens up the avenue for utilisation of this waste air to generate power through installation of wind turbine. Thus based on this audit finding, an innovative pilot project was executed at GORUNGA TEA FACTORY, where the wind turbine was installed and successfully commissioned to re – generate power from the waste air of the enclosed type of withering trough. This is probably for the first time in the history of Tea Industry, at least in this region and has thus opened up the opportunity to harness power from both waste air of withering trough and naturally available solar energy through installation of solar – aero generator hybrid power system in the tea factories. The adoption of this technology will help the tea factories to generate power from renewable sources, for which this technology, unlike other energy efficient technologies recommended for this Cluster, is eligible for grant from MNRE, which is rupees one lakh per kW generation.

This bankable DPR found eligible for grant from MNRE has been prepared, for a 3 kW capacity solar – aero generator hybrid power system with a back – up power supply for 14 hours. The key indicators of the DPR including the Project cost, debt equity ratio, monetary benefit and other necessary parameters are given in table below;

S. No	Particular	Unit	Value
1	Project cost(considering MNRE subsidy)	` in lakh	2.88
2	Electricity Regeneration	MWh/year	18.9
3	Monetary benefit per year	` in lakh	1.41
4	Simple payback period	Years	2.04
5	NPV	` in lakh	2.53
6	IRR	%age	33.80
7	ROI	%age	26.47
8	DSCR	Ratio	2.06
9	CO <sub>2</sub> Reduction	Tonne /Annum	19.47
10	Procurement & Implementation schedule	Weeks	8

**The projected profitability and cash flow statements indicate that the project implementation will be financially viable and technically feasible solution for Jorhat Tea cluster.**

## ABOUT BEE'S SME PROGRAM

Bureau of Energy Efficiency (BEE) is implementing a BEE-SME Programme to improve the energy performance in 25 selected SMEs clusters. Gujarat Dairy Cluster is one of them. The BEE's SME Programme intends to enhance the energy efficiency awareness by funding/subsidizing need based studies in SME clusters and giving energy conservation recommendations. For addressing the specific problems of these SMEs and enhancing energy efficiency in the clusters, BEE will be focusing on energy efficiency, energy conservation and technology up-gradation through studies and pilot projects in these SMEs clusters.

***Major activities in the BEE -SME program are furnished below:***

### ***Activity 1: Energy use and technology audit***

The energy use technology studies would provide information on technology status, best operating practices, gaps in skills and knowledge on energy conservation opportunities, energy saving potential and new energy efficient technologies, etc for each of the sub sector in SMEs.

### ***Activity 2: Capacity building of stake holders in cluster on energy efficiency***

In most of the cases SME entrepreneurs are dependent on the locally available technologies, service providers for various reasons. To address this issue BEE has also undertaken capacity building of local service providers and entrepreneurs/ Managers of SMEs on energy efficiency improvement in their units as well as clusters. The local service providers will be trained in order to be able to provide the local services in setting up of energy efficiency projects in the clusters

### ***Activity 3: Implementation of energy efficiency measures***

To implement the technology up-gradation project in the clusters, BEE has proposed to prepare the technology based detailed project reports (DPRs) for a minimum of five technologies in three capacities for each technology.

### ***Activity 4: Facilitation of innovative financing mechanisms for implementation of energy efficiency projects***

The objective of this activity is to facilitate the uptake of energy efficiency measures through innovative financing mechanisms without creating market distortion.

## **1 INTRODUCTION**

### **1.1 Brief about Jorhat Tea Cluster**

#### ***About Jorhat Tea Cluster***

This SME cluster chosen for BEE's SME cluster development program comprises of the tea factories located in the erstwhile undivided Jorhat district of upper Assam that is presently comprised of Jorhat and Golaghat districts. The Jorhat Tea Cluster has about 150 tea factories. Majority of these tea factories have their own plantations, while the tea factories not having their own plantations depends on the tea gardens that does not have tea factories. The tea factories having their own plantation are owned either by group companies like APPL, Williamson & Magor, etc or by families having ownership through inheritance. These tea factories were mostly established during pre independence period. Whereas the tea factories which does not have their own plantation were established after the late 80's and are owned by first or/and second generation entrepreneurs.

#### ***Existing Production Process:***

The tea factories under Jorhat Tea cluster produces mainly produces CTC (Cut, tear and curl) and Orthodox type of tea. For the production of CTC type of tea the green tea leaves are shredded and then cut, tear and curled in the CTC (cutting, tearing and curling) machine. Whereas for the production of orthodox tea the green tea leaves are twisted through continuous circular motion of the rollers of the rolling machine. But for both these types of tea being manufactured in this cluster, the tea leaves are dried in dryers to remove the moisture before the made tea is finally sorted and packed. The drying process is the most energy intensive and to carry out the drying, the tea factories of this cluster use either coal or natural gas as fuel.

The pictorial representation of the tea manufacturing process that is being presently followed in Jorhat Tea Cluster is depicted in ANNEXURE 1.

#### ***Withering:***

The green tea leaves plucked from the garden are first withered to remove the surface moisture and partially the internal moisture. Withering promotes the dissipation of heat generated due to continuous respiration. The withering process which takes about 10 hours on an average, reduces the moisture content of green leaves to 55% in case of orthodox tea and to 70% in case of CTC tea production.

In Jorhat tea Cluster two types of withering process is being adopted by the tea factories. The first is the "Open Trough Withering" and second is the "Enclosed Trough

Withering”. In the first case, the area over the withering trough is kept open and the air from the withering fan passes from the bottom of the withering trough and released to the environment through the tea leaves. In the second case, the area over the withering trough is enclosed and the air from the withering fan is released to the environment through a single outlet after being passed through the tea leaves.

***CTC:***

In this process the withered tea leaves are shredded in the rotor – vane and then cut torn and curled in the CTC machine. During this process the enzymes of the tea leaves are released in the rotor – vane and the curling of the tea leaves initiates the fermentation process. Most of the juice that comes out of the tea leaves during shredding in the rotor – vane is evaporated due to friction in the CTC machine, for which the moisture content in the tea leaves after CTC is reduced from 70 % to 55 %.

***Rolling:***

This process after withering is adopted by tea factories to produce orthodox type of tea. The chemical compounds of the tea leaves are released to initiate oxidation in the fermentation process. Rolling twist the leaves and at the same time, breaks the leaf to release enzymes for oxidation.

***Fermentation:***

This is the least energy intensive step in the entire tea manufacturing process. During the fermentation process the tea leaves are left for oxidation, to which there occurs notable chemical as well as physical change. The color of the tea leaves is changed to reddish brown. The flavor and liquor of the tea leaves is attained in this stage.

***Drying:***

The fermented tea particles are dried or fired to arrest the fermentation and to reduce the moisture to about 3%. Clean and odorless hot air is passed through the fermented tea particles in dryers.

The temperature of the hot air varies between 90<sup>0</sup> – 160<sup>0</sup>C depending on the type of dryer. Drying or firing is a thermal energy intensive operation that also consumes electrical energy to drive blowers and dryers.

Drying is a critical process that decides the final product quality of black tea. Two types of dryers are used in the tea industry: - Endless Chain type (ECP) dryer or Fluidized Bed Dryer (FBD).

In the ECP dryer, tea particles are spread over continuously moving chain – type trays through which hot air flows. The trays move from top to bottom while the hot air is blown from the bottom. The temperature of hot air is about 90<sup>o</sup>. The ECP dryer has an advantage to dry both leafy grades and powered grades. In the FBD, tea particles are pneumatically fluidized by hot air at 140 – 160<sup>o</sup>C. Uniform drying is ensured in FBD and better quality tea could be produced. This is also more energy efficient method compared to ECP dryers with less mechanical controls.

## 1.2 Energy Performance in Existing Situation

### 1.2.1 Energy Consumption Profile

For the purpose of tea processing, both electrical as well as thermal energy are required. In the tea factories of Jorhat Tea Cluster, the electrical energy requirement is fulfilled by electrical power available through grid whereas the main source of thermal energy is either coal or Natural Gas.

The summary of the annual energy consumption in different production capacities of the tea factories of this cluster that uses coal as the thermal energy source as revealed during the energy audit is given in Table – 1 below;

**Table1: Annual Energy Consumption of Tea factories using coal**

Parameter	Unit	Up to 500 MT of made tea	500 – 1500 MT of made tea	Above 1500 MT of made tea
Annual electrical energy consumption	kWh	221197.4	688252.8	862896.8
Annual coal consumption	MT	390.64	1107.21	1457.63
Annual HSD consumption	KL	27.66	88.69	136.43
Total Annual Energy consumption	MCal	2, 034, 504	5, 869, 315	7, 923, 604
Total Annual Energy consumption in one unit of the different capacity	Kloe	222.5	646.1	866.6
Average annual Made Tea production	MT	450	1000	1900

And the summary of the annual energy consumption of the tea factories of this cluster that uses NG as the thermal energy source is given in Table – 2 below;

**Table2: Annual Energy Consumption of Tea factories using Natural Gas**

Parameter	Unit	Up to 500 MT of made tea	500 – 1500 MT of made tea	Above 1500 MT of made tea
Annual electrical energy consumption	kWh	234896.8	656332.6	805998.7
Annual NG consumption	Scum	216602	431594.8	629896.2
Annual HSD consumption	KL	30	92	145
Total Annual Energy consumption	MCal	2, 581, 390	5, 627, 756	8, 190, 163

Parameter	Unit	Up to 500 MT of made tea	500 – 1500 MT of made tea	Above 1500 MT of made tea
Total Annual Energy consumption in one unit of the different capacity	Kloe	258.1	562.8	819.0
Average annual Made Tea production	MT	480	960	2100

### 1.2.2 Average Production

Tea factories are agro based industries, and the operation of the tea factories depends on the availability of the tea leaves in the tea gardens. The tea factories depends on either their own in – house production of green tea leaves or on green tea leaves plucked from tea gardens without factories or both. The peak production season for tea factories in Jorhat Cluster starts with the beginning of spring, i.e, from the month of March – April and lasts till the end of autumn or beginning of winter, i.e., till the month of October – November. During this period most of the tea factories run on round the clock basis as the green tea leaves cannot be stored. The tea factories remain non – operational for about two to three months in a year between the months of December to March. The average tea production in the tea factories of Jorhat Cluster where Energy Audits were carried out is about 1002 tonnes of made tea per annum.

### 1.2.3 Specific Fuel Consumption & Specific Electricity Consumption

Similar to any other type of industry, the specific energy consumption in the tea factories of this cluster also depends on the scale of production, which has been evaluated during the energy audit. Thus keeping this into consideration, the tea factories of this cluster is broadly divided into three groups and the specific energy consumption is evaluated separately.

In this context it is noteworthy to mention that bifurcation of the tea factories base on production is specific to this report only and there is no official notification by any authorized bodies in this regard. The specific energy consumption by the tea factories is given in Table – 3 below;

**Table3: Specific energy consumption of tea factories**

Type of tea factory	kWh/ kg of made tea	Kgs of coal/ kg of made tea	Liters of HSD/ kg of made tea	Scum of NG/ kg of made tea
Large tea factory	0.55	0.72	0.07	0.32
Medium tea factory	0.65	0.82	0.08	0.39
Small tea factory	0.85	1.02	0.09	0.51



### 1.3 Identification of Technology/ Equipment:

#### 1.3.1 Present Withering Method:

Withering is the first and the foremost step in tea manufacture. The process of withering involves blowing of air through the freshly plucked tea leaves to evaporate the moisture content in the tea leaves so as to bring about physical as well as chemical change in the tea leaves for subsequent processing stages. For the purpose of withering, two types of withering trough are used in the tea factories of Jorhat Cluster, namely, open trough and enclosed trough.

In open trough withering, the tea leaves are spread over a perforated bed and air is blown from the bottom to the top through the tea leaves. This makes the tea leaves in the bottom layer to wither first. So to wither the tea leaves in the top layer, the fan is rotated in the reverse direction and the air is sucked from the top.

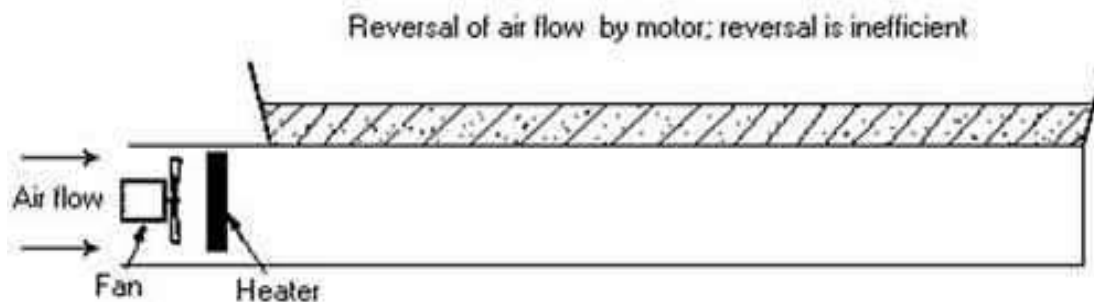

**Figure1: Open Trough Withering**

In case of enclosed trough withering, the tea leaves are spread over the perforated bed are enclosed by raising the sides of the withering trough and using a cover on the top of the bed. This is designed to create a plenum chamber on top of the leaf bed as well. In this case the fan is always made to blow air only in the forward direction and air can be made to pass either from top to the bottom or from bottom to the top with damper and shutter control at the air entry and exit points respectively without reversing the direction of the fan.

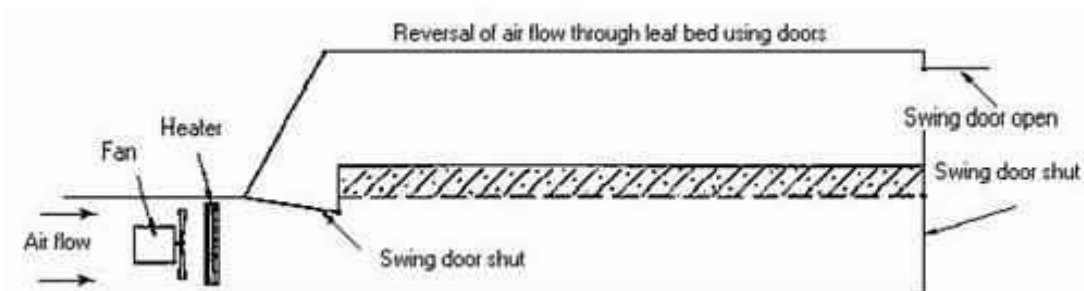

**Figure 2: Enclosed Trough Withering**

Unlike in case of open trough, in enclosed trough withering, the moisture laden dense waste air coming out of the withering trough is channelized through single outlet. During the energy audit phase it was found that the average speed of the waste air coming out of the enclosed type of withering trough is 10.68 m/s, as detailed in Table 4 is sufficient to operate an aero generator.

The technical feasibility of operation of aero – generator through utilization of the waste air coming out from the enclosed type of withering trough can be further optimized if the naturally available solar energy can be harnessed. For this reason the installation of solar – aero generator hybrid power system has been suggested for implementation in the tea factories of Jorhat Tea Cluster.

### 1.3.2 Role of Withering in Tea Manufacturing Process

During the process of withering both physical as well as chemical changes are brought about in the tea leaves, which are very important in determining the quality of the tea. The physical change in withering is brought about in the form of loss of moisture and making the tea leaves flaccid. On the chemical front, there occurs bio – chemical changes in the tea leaves during withering so that further processing of the tea leaves can be initiated. The essence of good withering is high hygrometric temperature difference and low dry bulb temperature. Also there should be uniform distribution of air through the tea leaves so that the tea leaves both in the upper layer as well as the bottom layer gets withered simultaneously. But in open trough withering it is difficult to get uniform distribution of air resulting is non – uniform withering. This difficulty can be overcome in enclosed trough withering. For this reason enclosed trough withering is increasingly being adopted by the tea factories of this cluster.

### 1.4 Baseline establishment:

This proposed technology will harness naturally available solar energy and waste air from the enclosed type of withering trough to generate power. Thus the prime baseline parameters considered for evaluation of the techno – economic feasibility of this technology is as tabulated in Table 4 below

**Table 4: Baseline Parameters**

S. No.	Parameters	Baseline
1.	Solar Radiation	Naturally Available
2.	Wind	Waste air available from enclosed type of withering troughs
3.	Availability of both waste air and solar radiation for regeneration	250days in a year
4.	Availability of waste air from withering per day	10 hours per day

S. No.	Parameters	Baseline
5.	Availability of only waste air and no solar radiation	30days in a year
6.	Number of withering fans in each withering trough	02 numbers
7.	Rated capacity of the withering fan motor	7.5 h.p
8.	Type of withering trough	Enclosed type.

The other baseline parameters that are considered are detailed in ANNEXURE 2.

#### 1.4.1 Baseline from the Existing System

The electrical energy consumption required for blowing air through the green tea leaves for the purpose of withering depends on the following parameters;

- Withering fan size.
- Withering fan type.
- Rated capacity of the motor associated with the withering fan.
- Total Hours of operation of the withering fan.
- Volume flow rate of the withering air required.

The moisture laden air that moves out from the withering fan has kinetic energy that is imparted by the withering fans. To calculate the kinetic energy of the moving air (i.e., wind), it is considered that it has a cross sectional area of “A” and of thickness “D”. And this air parcel sweeps the turbine blades with a velocity “V”. Considering the mass of this air parcel as “M”, the kinetic energy is expressed by the following equation;

$$\begin{aligned}
 \text{Kinetic Energy} &= \frac{1}{2} * M * V^2 \\
 &= \frac{1}{2} * \text{Density} * \text{Volume} * V^2 \\
 &= \frac{1}{2} * \text{Density} * A * D * V^2
 \end{aligned}$$

If time “T” is taken by this air parcel (of thickness “D”) to sweep the turbine blades, then

$$\text{Thickness, D} = V * T$$

Thus,

$$\text{Kinetic energy} = \frac{1}{2} * \text{Density} * A * T * V^3$$

And,

$$\text{Power of the wind} = \frac{1}{2} * \text{Density} * A * V^3$$

Wind Power Density, which represents the power of the wind per unit cross sectional area of the air is given as below;

$$\text{Wind Power Density} = \frac{1}{2} * \text{Density} * V^3$$

Now, if the density of the moisture laden waste air is considered as  $1.30 \text{ kg/ m}^3$  and the velocity of the waste air is taken as  $9.54 \text{ m/s}$ , then applying the above formula the potential wind power density is calculated as  $564 \text{ Watt/ m}^2$ .

Thus considering the density of the moisture laden waste air as  $1.30 \text{ kg/ m}^3$ , and based on the data regarding the speed of the waste air that was collected during the energy audit, in the existing scenario the potential Wind Power Density of the tea factories having enclosed withering trough is as tabulated in Table 5 below;

**Table 5: Average speed and corresponding Wind Power Density of the tea factories**

Tea Factory with enclosed withering trough	Average speed of the waste air (m/ sec)	Wind Power Density (Watt/ m <sup>2</sup> )
Factory 1	9.54	564
Factory 2	8.71	430
Factory 3	10.03	656
Factory 4	12.55	1285
Factory 5	8.76	437
Factory 6	10.48	748
Factory 7	9.91	633
Factory 8	14.03	1795
Factory 9	11.26	928
Factory 10	12.86	1382
Factory 11	9.45	549
Average Speed of the Waste Air, m/s		<b>10.68</b>
Average Wind Power Density, Watt/ m <sup>2</sup>		<b>855</b>
Potentiality of Power Generation From Waste Air, kWh/ m <sup>2</sup>		<b>2394</b>

The technical justification for installation of this technology is to harness this waste air potentiality of  $2394 \text{ kWh/ m}^2$  due to operation of enclosed type of withering trough for 10 hours per day and for 280 days in a year. This is apart from the naturally available solar energy.

#### 1.4.2 Design and Operation Parameters

To remove the moisture during withering, air is blown through the green tea leaves by means of axial fans. In absence of any standard norms with regard to the number of withering fans per withering trough, the tea factories of this Cluster has either one or two numbers of withering fans in a withering trough depending on various parameters, viz., size of the withering trough, type of fan blade used (i.e., cast aluminum, or FRP), horse power of the withering fan motor. Due to absence of any standard norms, this report is

prepared on the basis that each withering trough has 02 (two) numbers of withering fans with each fan being powered by 5.63 kW induction motor.

Again withering being the first process after the green leaves reaches the factory for processing is very important from the quality point of view. The quantity of moisture that is required to be removed from the tea leaves is not only dependent on the weather but also on the type (whether CTC or Orthodox) and quality that is required to be produced. Thus the batch time for withering varies from 10 hours to 14 hours. But during the preparation of this report a conservative approach has been adopted for which the batch time for withering has been considered as 10 hours.

### 1.4.3 Specific Electricity Consumption during Withering:

The specific electricity consumption in withering for tea factories are calculated on the following basis;

$$\text{Sp. Electricity Consumption} = \frac{\text{Electricity Consumption during withering (kWh)}}{\text{Amount of Made Tea Produced (kg)}}$$

As given above, the specific electricity consumption by the tea factories of Jorhat Tea Cluster is 0.50 kWh per kg of made tea. Out of this average kWh consumption of electrical energy, withering consumes about 0.13 kWh of electrical energy.

## 1.5 Barriers for Adoption of Solar – Aero Generator Hybrid Power System

### 1.5.1 Technological Barrier

- Due to absence of any scientifically designed operator training program, the operation and maintenance protocols for optimum utilization of thermal energy equipment are not followed.
- Though withering after drying is the most energy intensive process during tea manufacturing consuming both electrical as well as thermal energy, yet the awareness level in making these process energy efficient needs enhancement.
- Majority of the unit's entrepreneurs in Jorhat tea cluster do not have any in – depth technical expertise and knowledge on energy efficiency, and are dependent on local technology suppliers or service companies, who normally rely on established and commonly used technology. The lack of technical know – how has made it difficult for the factory owners to identify the most effective technical measures.

- Most of units in Jorhat tea cluster have been established several years ago when energy efficiency was not important issue for the operation of a plant. They are operating with outdated technology and low – end technologies.
- As majority of the entrepreneurs in cluster are not aware of the energy losses in the plant, there may be a strong feeling that the energy efficiency initiatives in manufacturing facility can have a cascading effect of failure in critical production areas directly or indirectly connected if the intended performance of the replaced/ retrofitted equipment falls below design values
- There is a strong feeling in the tea factory entrepreneurs that, energy efficiency initiatives are difficult and they do not wish to take the risks such as business interruption due to production loss vis-a-vis the drive to save energy. These can however be overcome by motivating them to attend the awareness programs and use the detailed report on the benefits of the measures identified and cost benefit analysis. Further, sourcing of expertise on maintenance service provider or training by the equipment supplier will definitely overcome the barriers.

### **1.5.2 Financial Barriers**

- The cost of new technology is high. There is inadequate data on return on investment from energy saving alone. This creates barriers to financial decision making for acquisition of new technology.
- Banks, although willing to lend to the sector are unable to take decisions about lending in the absence of information about techno economic feasibility of energy saving equipment.

### **1.5.3 Skilled Manpower**

- Skilled manpower is locally available to run the machines available in Jorhat Cluster. However, there is hardly any innovation regarding energy usage by the workers in these enterprises and the production process remains traditional. This is one of the lacunae of the Jorhat Tea Cluster.
- Specialized training with local service providers for better operation and maintenance of equipments, importance of the energy and its use will create awareness amongst workforce. These programs should be organized with equipment suppliers.

#### **1.5.4 Barriers Specific towards adoption of this technology**

- Solar – aero generator hybrid power system, though a proven technology approved by MNRE for clean power generation but in case of the tea factories the waste air from enclosed withering trough instead of natural air will be used for generation of power from wind. As this is for the first time in the history of tea industry in Assam, so the acceptance by the industry may require some time as the initial capital involvement is moderately high.
- This technology can be implemented only tea factories having enclosed type of withering trough. And in tea factories having open type of withering trough the implementation of this technology will not be possible.

## 2 PROPOSED TECHNOLOGY FOR RENEWABLE POWER GENERATION

### 2.1 Detailed description of the proposed system

#### 2.1.1 Description of technology

The solar – aero generator hybrid power system will harness the naturally available solar energy as well as convert the kinetic energy of the waste air coming out of the enclosed type of withering trough to generate electrical power. This is an integrated system having the following

- Solar Panel to harness naturally available solar energy
- Aero Generator to harness the waste air from the withering trough.

The solar panel that will be installed in this hybrid system will be similar to the normally available solar photovoltaic panels of 175 W (24 V). The proposed system will harness the Power generated from both the sources and would be able to discharge power of 3kW for 24 hours from the battery bank. The Aero generator will provide power for 10 hours and at mean time the solar generator will charge the battery bank which will provide backup for rest 14 hours.

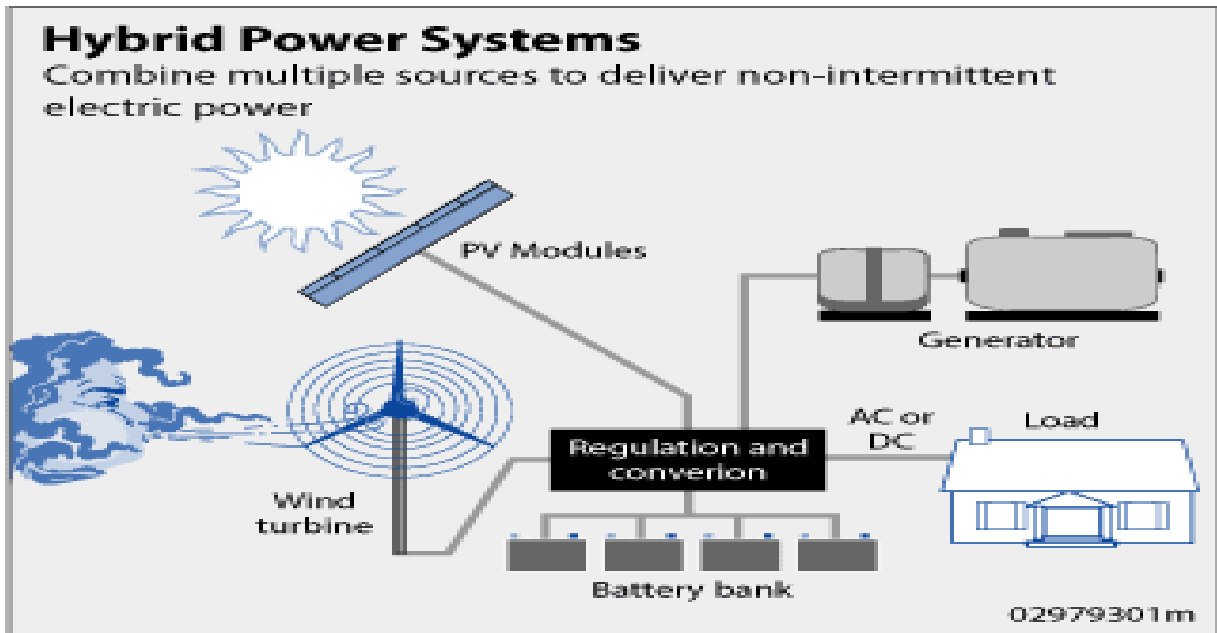

Figure 3: Hybrid power System

#### 2.1.2 Operation of the aero generator

The hybrid Aero generator system will be able to discharge power of 3kW for 24 hours for the period of 250 days and 10 hours for 30 days when solar radiations are in available from the Battery bank. Aero generators are devices that convert the kinetic



energy of the wind into mechanical energy of the rotating shaft which is then converted into electrical energy by a generator attached with the rotating shaft.

The efficiency of the aero generator is given by the following equation;

$$\frac{\text{Mechanical Power in turbine shaft}}{\text{Power of the wind}} \times \frac{\text{Electrical Power generated}}{\text{Mechanical power in turbine shaft}}$$

= Mechanical Efficiency X Electrical Efficiency

The Mechanical efficiency of the aero generator is governed by Betz Law, which states that at the maximum 59% of the wind energy can be converted into mechanical energy of the rotating shaft attached with the wind turbine.

Again considering the efficiency of converting the mechanical energy of the rotating shaft into electrical energy through the generator as 85%, the maximum achievable energy that can be converted into electrical energy in the aero generator is 50.15 % of the energy of the wind striking the fan blades of the aero generator.

In this particular case, the wind striking the blades of the aero generator is not natural wind, but is produced by the withering fans. For this the overall efficiency in this particular case is as given by the following equation;

$$\text{Overall Efficiency} = \frac{\text{Power generated from the aero generator}}{\text{Power required in producing the wind}}$$

In the demo project that was carried out, the aero generator was operational by the waste air generated from two withering fans with each fan being powered by 5.63 kW capacity motor is required. Hence, for this system to be operational, the power required to produce the wind is 11.26 kW (5.63 kW multiplied by 2), thus the overall efficiency of the aero generator of this hybrid system works out to be 17.76%.

**2.1.3 Equipment specification**

In absence of any standard norms regarding the number of withering troughs required for a particular production capacity and also due to absence of any standard norms defining the layout of the withering troughs in the tea factories, this DPR is prepared considering a single unit of solar – aero generator hybrid power system of 3 kW capacity.

This solar – aero generator hybrid power system is designed to provide power for 24 hours when the withering fans are operational considering that the average hours of operation of withering fan is 10 hours per day. And during the period when solar energy

is not available with the withering fans being only operational, this system will provide power for only 10 hours in a day. This is an integrated system, and a single unit of this system comprises of the following components:

- 18 numbers of 175 W (24 V) solar photovoltaic panels to harness naturally available solar energy.
- 1 set of 3 kW capacity aero – generator control system to harness waste air.
- 1 set of 3 kW capacity controller
- Connectors
- Battery bank to provide back – up power supply for 14 hours.

The detailed specification of the aero generating system is given in ANNEXURE 4.

#### **2.1.4 Suitability or integration with existing process**

In this proposed technology, the waste air from the withering trough and naturally available solar energy will be utilized to produce electrical energy, so this technology in no way affects the tea manufacturing process, as this waste air is otherwise released to the environment without any utilization. Also the power that will be produced from the wind turbine will be delivered in the right quality in terms of voltage, amperage and frequency for which this produced power can be utilized for partial fulfillment of the electrical energy requirement during the tea manufacturing process. Thus this proposed technology can be suitably integrated into the existing process of tea manufacturing in the Jorhat Tea Cluster.

#### **2.1.5 Superiority of solar – aero generator hybrid power system:**

During the periods of the year when the factory is operative, this proposed technology will harness power both from the waste air by the aero – generator and from the solar radiation by the solar panel simultaneously, which will not only charge up the battery bank to provide back – up power supply for about 14 hours but will also be able to meet process power requirement for the time period of operation of the withering process. As withering process continues for about 10 hours in a day, so during these periods of the year the proposed technology will provide electrical power for about 24 hours a day. And for the periods of the year when the factory is not operative, though the aero – generator cannot be functional, yet solar radiation can be harnessed through the solar panels for charging the battery bank and back – up power supply from the battery bank can be obtained for about 14 hours in a day.

This proposed technology can generate power irrespective of the operation of the factory but only subject to the availability of either waste air or solar radiation or both.

**2.1.6 Availability of the technology:**

Though power generation from waste air is introduced for the first time in the tea factories of Jorhat Tea Cluster, but the generation of power using solar – aero generator hybrid power system is as established technology and is easily available under the promotional steps taken up by even by MNRE to generate off – grid power.

**2.1.7 Service Providers**

The technology suppliers are locally available at Guwahati but for the Scope of the technology in the SME cluster service providers from Kolkata has been taking interest in the technology.

**2.1.8 Terms of sales**

Services will provide the turnkey consultancy for installation and commissioning of the equipments procured, with equipment warranty from Service provider. Rest terms of sales provided in annexure 8.

**2.1.9 Process down Time during Implementation:**

With the experience of existing system being installed at a Tea Factory, the installation and commissioning of this equipment will require about 04 days and this technology can be installed without disturbing the tea manufacturing process. Thus installation and commissioning of this technology can be done at any time of the year and there is no process down time during implementation.

**2.2 Life Cycle Assessment:**

The life of the solar – aero generator hybrid power system can safely be taken as 10 years.

### 3 ECONOMIC BENEFITS DUE TO THE PROPOSED TECHNOLOGY

The economic benefits as stated above are calculated for a single unit of solar – aero generator hybrid power system. During calculation of the economic benefits from installation of this solar – aero generator hybrid power system, it is considered that the solar energy will be available naturally and the wind required to operate the aero – generator will be available from two numbers of withering fans, each powered by motors of 5.63 kW, 960 rpm motor and operating at 90 % loading.

#### 3.1 Technical Benefits

##### 3.1.1 Fuel Savings per Year

Though generation of renewable energy through installation of this system will help save the HSD consumption due to reduced load on the DG set, yet the exact amount of savings in HSD is not evaluated, mainly for the reasons due to lack of proper data regarding electrical energy produced from the burning of HSD in the DG.

##### 3.1.2 Electrical Power Generation per year

The growth of the tea leaves starts from the Spring and lasts till the end of Autumn. The tea factories thus remains operational from the months of March – April to October – November, i.e., during the periods when the unit starts operating as first rainfall of the year takes place in the area in which this cluster is located. Power will be generated both from the aero – generator and the solar panel during the periods when the factory is operational, and thus the proposed system will generate power for 24 hours during the periods when the factory is operational for the period of 250 days. During the periods when solar radiations are not available the system will charge the battery bank that will easily deliver power for 10 hours a day for 30 days. The total electrical power regeneration from this proposed system is as detailed in Table – 6 below;

**Table 6: Electrical Power Regeneration by the proposed technology**

Availability of	No. of days per year	kWh generated/ day	kWh generated/ year
Both waste air and solar energy	250	72	18000
Only waste air and no Solar energy	30	30	900
<b>Total Power Generated Per Year</b>			<b>18900</b>

#### 3.2 Monetary Benefits

For the purpose of calculating the monetary benefits, the cost of electricity per kWh is 7.45 is considered that is Based on this energy price, the monetary benefits that can be

achieved through the installation of solar–aero generator hybrid power system to generate power are given in Table 7 below; the system will save about ` 1.41 lakh per year.

**Table 7: Monetary benefits from the proposed technology**

Particulars	Quantity Saved	Rate ( ` )	Amount in ` Saved per annum
Fuel	NIL	Not Applicable	NIL
Electricity	18900 kWh	7.45 per kWh	140805
Total saving in energy cost			140805

### 3.3 Social Benefits:

#### 3.3.1 Improvement in Working Environment in the Tea Factory

Due to installation of this system the emergency system, viz., security lighting, etc. requiring electrical energy will not be dependent either on grid power or on Diesel Gen set, thus helping towards fulfillment of the emergency requirement round the clock. This will help towards building a secure and improved working environment as this system is more reliable than grid power.

#### 3.3.2 Improvement in the Skill of the Worker

Technical skills of persons will definitely be improved. As the training will be provided by equipment suppliers which improve the technical skills of manpower required for operating of the equipment and also the technology implementation will create awareness among the workforce about energy efficiency and energy saving

### 3.4 Environmental Benefits

#### 3.4.1 Reduction in Effluent Gases

As the withering process do not emit any effluent gases, so the application of this technology will not have any impact on the reduction of effluent gases.

#### 3.4.2 Reduction in GHG emission such as CO<sub>2</sub>, NO<sub>x</sub>, etc.

It is estimated that the proposed technology will generate 18900 kWh of power per year by utilization of the waste air from the withering trough and naturally available solar radiation. This being a clean source of power generation, the estimated reduction in CO<sub>2</sub> emission due to the adoption of this technology will be 19467 kg of CO<sub>2</sub> per installation. The reduction in the CO<sub>2</sub> emission is evaluated by considering that 1 kWh of clean power generation will reduce CO<sub>2</sub> emission by 1.03 kg.

## 4 IMPLEMENTATION OF THE PROPOSED TECHNOLOGY

### 4.1 Cost of Technology:

The capital expenditure that will be required for the installation and commissioning of this technology is as detailed in Table 8 below;

**Table 8: Capital expenditure for the proposed technology**

Particulars	Rating	Quantity	Amount, `
Solar Panel (Including Bracket)	175 W (24 V)	18 Nos.	345000
3 kW Wind Turbine Control System		1 Set	
Controller	3 kW	1 Set	
Connector		As required	
Battery Bank with 14 hours back up			220000
Sub – Total (`)			565000
VAT/ CST @4% (`)			22600
Total Value for 3 kW System			587600

### 4.2 Arrangement of Fund

#### 4.2.1 Financial Assistance

For the Implementation of this project in Tea factory financial assistance is being provided both by Ministry of Micro, Small and Medium Enterprises, Government of India and MNRE, Government of India. The amount of financial assistance provided by each of these two ministries is as discussed below;

#### a) Assistance from MoMSME, Government of India:

This ministry of Government of India provides a capital subsidy of 25% of the total project cost. The capital subsidy from the Ministry of Micro, Small and Medium Enterprises works out to be ` 146900.

#### b) Central Financial Assistance from MNRE, Government of India:

This being a renewable project, so this project is eligible for financial assistance from MNRE. As per the available schemes under this Ministry, the Central Financial Assistance is `100000 per kW of electrical energy generation through solar – aero generator hybrid power system. This proposed technology has a generation capacity of 3 kW of electrical energy. Thus the Central Financial Assistance available from MNRE for this proposed technology is ` 300000.

#### c) Financial Assistance Considered:

From the above discussion in paragraph 4.2.1a and 4.2.1b above, it is found that the subsidy from MNRE is higher than that from the MoMSME, so the financial assistance from the MNRE is considered.

Of the above financial assistance provided by the two Ministries, the financial assistance that will be received by the tea factories for implementation of this technology is from MNRE. For this the financial assistance that will be received by the tea factories for the implementation of this technology is considered as ` 300000.

#### **4.2.2 Entrepreneurs' Contribution**

The entrepreneur requires contributing 25% of the total capital investment and this amount to ` 72000.

#### **4.2.3 Loan Amount**

The balance capital requirement of 75% will be arranged by means of loans refinanced by Small Industries Development Bank of India through any of the scheduled commercial banks. Thus the loan amount will be ` 216000.

#### **4.2.4 Terms and Conditions of the Loan**

The terms and conditions of the loan with regard to the financial aspect of the loan are;

- Interest rate of the loan is @10% per annum on a reducing balance basis, which is SIDBI's interest rate for energy efficient projects.

#### **4.3 Financial Indicators**

The financial indicators for this proposed technology is calculated on the following basis;

- For calculating the financial indicators, the subsidy from MNRE is taken into consideration.
- To arrive at a more competitive evaluation, the rise in the energy price is not taken into consideration, as monetary value of the savings is directly proportional to the energy price.
- The cost of maintenance and operation is taken as 2% of the capital cost of the solar – aero generator with a yearly increase @5%.

##### **4.3.1. Cash flow analysis**

Profitability and cash flow statements have been worked out for a period of 8 years. The project is expected to achieve monthly savings of ` 1.41 lakhs based on the assumptions as mentioned above.

Considering the above assumptions, the net cash accrual starts with ` 0.98 lakh in the first year of operation and to ` 4.90 lakh at the end of eighth year of operation.

##### **4.3.2. Simple payback period**

The Simple Payback period is about 2.04 years or about 21 months

**4.3.3. Net Present Value (NPV)**

The Net present value of the investment at 10% works out to be ₹ 2.53 lakh.

**4.3.4. Internal rate of return (IRR)**

The after tax IRR of the project works out to be 33.80%. Thus the project is financially viable

**4.3.5. Return on investment (ROI)**

The average return on investment of the project activity works out at 26.47%. Financial indicator of proposed technology is furnished in Table 9 below:

**Table 9: Financial indicators of proposed technology/equipment**

SN	Scenario	IRR	NPV	ROI	DSCR
1	Normal	33.80 %	2.53	26.47%	2.06

**4.4 Sensitivity analysis**

Sensitivity analysis to assess the cushioning affect of this energy efficient device is carried out in the following two scenarios;

- a) **Optimistic Scenario:** Under this scenario the financial projections are evaluated on the basis of 5% increase in the savings of electricity.
- b) **Pessimistic Scenario:** Under this scenario the financial projections are evaluated on the basis of 5% decrease in the savings of electricity.

The results of the sensitivity analysis as carried out based on the above two scenario is given in Table 10 as below;

**Table 10: Sensitivity Analysis**

Particulars	IRR	NPV (₹ in lakh)	ROI	DSCR
Normal	33.80 %	2.53	26.47%	2.06
5% increase in savings	36.15 %	2.80	26.67%	2.16
5% decrease in fuel savings	31.43 %	2.26	26.24%	1.95

**4.5 Procurement and implementation schedule:**

The procurement and implementation schedule is given in Annexure 6.

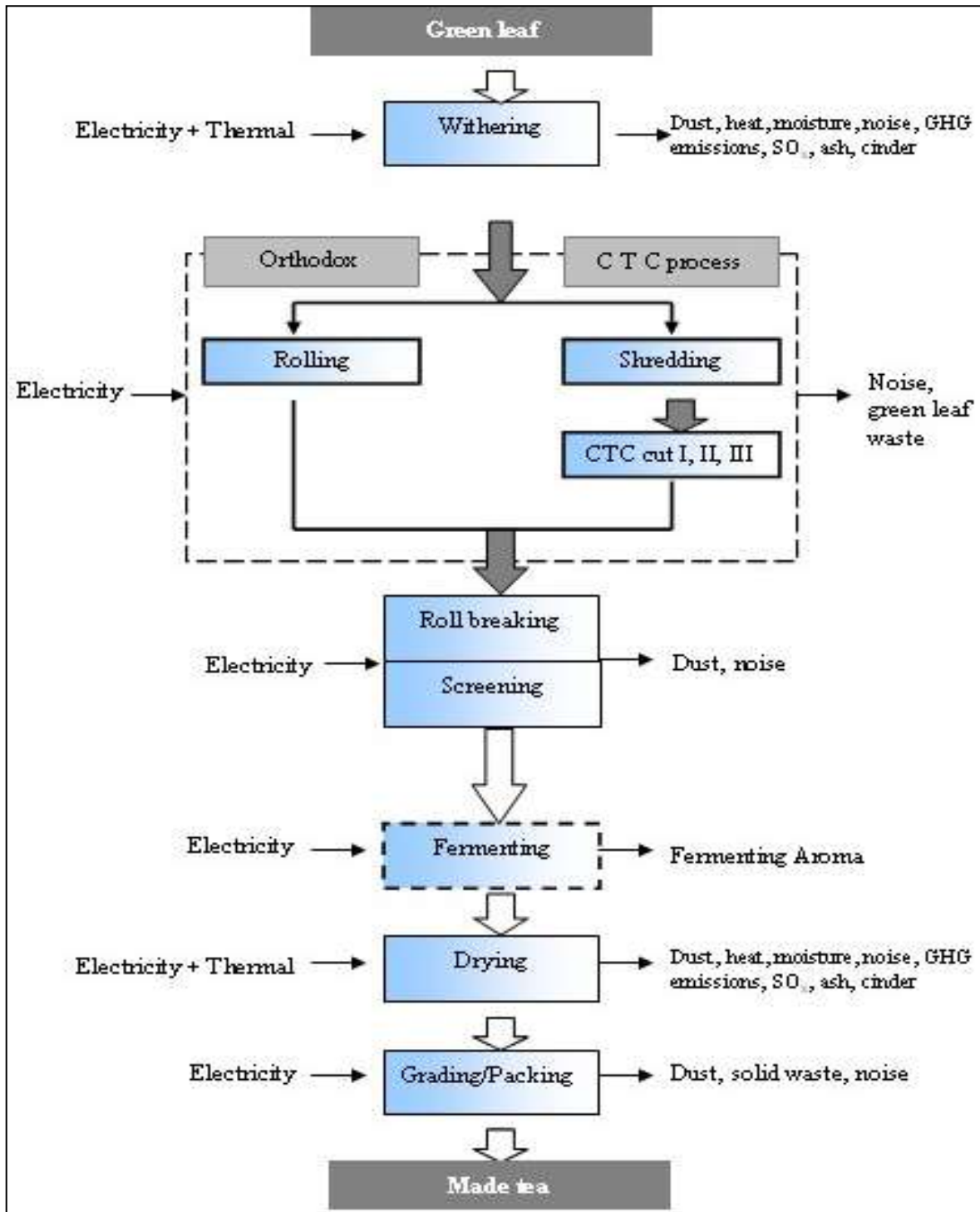

**Annexure 1: Process Flow Diagram**

**Annexure 2: Energy audit data used for baseline establishment**

S. No.	Parameter	Unit	Value
1	Average Production of made tea in cluster	MT/Year	1002
2	Average Electrical Power consumption in cluster	kWh/ Year	498000
3	Average Natural Gas Consumption in cluster	SCUM/ Year	537600
4.	Specific Electrical Energy Consumption in the cluster	kWh /kg of made tea	0.50
5	Specific Thermal Energy Consumption in the cluster	kcal / kg of made tea	3.86
6	Type of Withering Trough		closed
7	Type of withering fan blade		FRP
8	Size of Withering Fan blade	Inch	48
9	Rated capacity of the withering motor	h. p.	7.5
10	Number of withering fan used to power a single wind turbine	Number	03
11	Average speed of the waste air coming out from enclosed trough	m/s	10.68
12	Average operating days of withering	Days/ Year	280
13	Hours of withering carried per day	Hours/ Day	10
14	Average operating days of the system only on solar energy	Days/ Year	50
15	Hours of power supply available from the system when both solar as well as energy from waste air is harnessed	Hours/ Day	24
16	Hours of power supply available from the system when only solar energy is harnessed	Hours/ Day	14
17	Cost of Electrical Energy for the tea factories considered	₹./ kWh	7.45
18	Average annual potential power generation from waste air.	kWh/ m <sup>2</sup> / year	2394

**Annexure 3: Detailed technology assessment report**

S. No.	Parameter	Unit	Value
1	Capacity of the solar – aero generator hybrid power system	kW	3
2	Battery back – up	Hours	14
3	Total electric power generation from the solar – aero generator hybrid power system.	kWh/ Year	18900
4	Cost of electrical power considered	₹/ kWh	7.45
5	Total electrical power re – generated	₹in lakh/ Year	1.41
6	Cost for the project	₹In lakh	5.88
7	(-) MNRE Subsidy	₹ in lakh	3.0
8	Cost of implementation	₹ in lakh	2.88
9	Pay back	Years	2.04

**Annexure 4: Specification of Aero Generator**

PARTICULARS	UNIT	SPECIFICATION
Model No.	W	1000
Motor Model		MWHO10
Blade Diameter	M	32
Rotated Speed	Rpm	400
Rated Wind Speed	m/s	8
Rated Power	W	1000
Maximum Power	W	1500
Output Voltage	V	48
Start up wind speed	m/s	3
Operated Wind Speed	m/s	3 – 25
Security Wind speed	m/s	40
Height of Tower	m	6
Weight of Top Section	Kg	83
Controller Parameter		48V 60A
Tower Pole	Mm	75.4
REF Battery		4 Nos. of 12 V 150AH
20 D Container	Sets	50
40 D Container	Sets	110
Supply power for		Ice box, washer, TV, lighting, electric fan, charger, air - condition

**Annexure 5: Detailed Financial Calculation & Analysis for Financial Indicators**

Name of the Technology	SOLAR – AERO GENERATOR		
Rated Capacity	3 kW		
Details	Unit	Value	Basis
Installed Capacity	kW	3	
No of working days	Days	280	
<b>Proposed Investment</b>			
Solar - aero generator complete	` ( in lakh)	5.88	
Civil Work	` ( in lakh)	0.00	
Erection & Commissioning	` ( in lakh)	0.00	
Investment without EPC	` ( in lakh)	5.88	
(-) MNRE subsidy	` ( in lakh)	3.00	
Total Investment	` ( in lakh)	2.88	
<b>Financing pattern</b>			
Own Funds (Equity)	` ( in lakh)	0.72	Feasibility Study
Loan Funds (Term Loan)	` ( in lakh)	2.16	Feasibility Study
Loan Tenure	Years	5.00	Assumed
Moratorium Period	Months	6.00	Assumed
Repayment Period	Months	66.00	Assumed
Interest Rate	%age	10.00%	SIDBI Lending rate
<b>Estimation of Costs</b>			
O & M Costs	% on Plant & Equip	2.00	Feasibility Study
Annual Escalation	%age	5.00	Feasibility Study
<b>Estimation of Revenue</b>			
Electricity Saving through generation	kWh/Year	18900	
Cost of electricity	` / kWh	7.45	
St. line Depreciation	%age	5.28	Indian Companies Act
IT Depreciation	%age	80.00	Income Tax Rules
Income Tax	%age	33.99	Income Tax

**Estimation of Interest on Term Loan****` (in lakh)**

Years	Opening Balance	Repayment	Closing Balance	Interest
1	2.16	0.12	2.04	0.25
2	2.04	0.24	1.80	0.19
3	1.80	0.32	1.48	0.17
4	1.48	0.48	1.00	0.13
5	1.00	0.64	0.36	0.07
6	0.36	0.36	0.00	0.01
		2.16		

**WDV Depreciation****` (in lakh)**

Particulars / years	1	2
<b>Plant and Machinery</b>		
Cost	2.88	0.58
Depreciation	2.30	0.46
WDV	0.58	0.12

**Projected Profitability**

` (in lakh)

Particulars / Years	1	2	3	4	5	6	7	8
Electricity generation	1.41	1.41	1.41	1.41	1.41	1.41	1.41	1.41
Total Revenue (A)	1.41	1.41	1.41	1.41	1.41	1.41	1.41	1.41
<b>Expenses</b>								
O & M Expenses	0.06	0.06	0.06	0.07	0.07	0.07	0.08	0.08
Total Expenses (B)	0.06	0.06	0.06	0.07	0.07	0.07	0.08	0.08
PBDIT (A)-(B)	1.35	1.35	1.34	1.34	1.34	1.33	1.33	1.33
Interest	0.25	0.19	0.17	0.13	0.07	0.01	0.00	0.00
PBDT	1.10	1.15	1.18	1.22	1.26	1.32	1.33	1.33
Depreciation	0.15	0.15	0.15	0.15	0.15	0.15	0.15	0.15
PBT	0.95	1.00	1.02	1.06	1.11	1.17	1.18	1.17
Income tax	0.00	0.24	0.40	0.41	0.43	0.45	0.45	0.45
Profit after tax (PAT)	0.95	0.77	0.62	0.65	0.68	0.72	0.73	0.72

**Computation of Tax**

` (in lakh)

Particulars / Years	1	2	3	4	5	6	7	8
Profit before tax	0.95	1.00	1.02	1.06	1.11	1.17	1.18	1.17
Add: Book depreciation	0.15	0.15	0.15	0.15	0.15	0.15	0.15	0.15
Less: WDV depreciation	2.30	0.46	-	-	-	-	-	-
Taxable Profit	(1.20)	0.69	1.18	1.22	1.26	1.32	1.33	1.33
Income Tax	-	0.24	0.40	0.41	0.43	0.45	0.45	0.45

**Projected Balance Sheet**

` (In lakh)

Particulars / Years	1	2	3	4	5	6	7	8
Share Capital (D)	0.72	0.72	0.72	0.72	0.72	0.72	0.72	0.72
Reserves & Surplus (E)	0.95	1.71	2.34	2.99	3.67	4.39	5.12	5.84
Term Loans (F)	2.04	1.80	1.48	1.00	0.36	0.00	0.00	0.00
Total Liabilities (D)+(E)+(F)	3.71	4.23	4.54	4.71	4.75	5.11	5.84	6.56
<b>Assets</b>	<b>1</b>	<b>2</b>	<b>3</b>	<b>4</b>	<b>5</b>	<b>6</b>	<b>7</b>	<b>8</b>
Gross Fixed Assets	2.88	2.88	2.88	2.88	2.88	2.88	2.88	2.88
Less Accm. Depreciation	0.15	0.30	0.46	0.61	0.76	0.91	1.06	1.22
Net Fixed Assets	2.73	2.58	2.42	2.27	2.12	1.97	1.82	1.66
Cash & Bank Balance	0.98	1.66	2.12	2.44	2.63	3.15	4.02	4.90
TOTAL ASSETS	3.71	4.23	4.54	4.71	4.75	5.11	5.84	6.56
Net Worth	1.67	2.43	3.06	3.71	4.39	5.11	5.84	6.56
Debt Equity Ratio	2.83	2.50	2.06	1.39	0.50	0.00	0.00	0.00

**Projected Cash Flow**

` (In lakh)

Particulars / Years	0	1	2	3	4	5	6	7	8
<b>Sources</b>									
Share Capital	0.72	-	-	-	-	-	-	-	-
Term Loan	2.16								
Profit After tax		0.95	0.77	0.62	0.65	0.68	0.72	0.73	0.72
Depreciation		0.15	0.15	0.15	0.15	0.15	0.15	0.15	0.15
Total Sources	2.88	1.10	0.92	0.78	0.80	0.83	0.87	0.88	0.88

**Solar – Aero Generator Hybrid Power System (3 kW)**

<b>Application</b>									
Capital Expenditure	2.88								
Repayment Of Loan	-	0.12	0.24	0.32	0.48	0.64	0.36	0.00	0.00
Total Application	2.88	0.12	0.24	0.32	0.48	0.64	0.36	0.00	0.00
Net Surplus	-	0.98	0.68	0.46	0.32	0.19	0.51	0.88	0.88
Add: Opening Balance	-	-	0.98	1.66	2.12	2.44	2.63	3.15	4.02
Closing Balance	-	0.98	1.66	2.12	2.44	2.63	3.15	4.02	4.90

**IRR**

` (In lakh)

<b>Particulars / months</b>	<b>0</b>	<b>1</b>	<b>2</b>	<b>3</b>	<b>4</b>	<b>5</b>	<b>6</b>	<b>7</b>	<b>8</b>
Profit after Tax		0.95	0.77	0.62	0.65	0.68	0.72	0.73	0.72
Depreciation		0.15	0.15	0.15	0.15	0.15	0.15	0.15	0.15
Interest on Term Loan		0.25	0.19	0.17	0.13	0.07	0.01	-	-
Cash outflow	(2.88)	-	-	-	-	-	-	-	-
Net Cash flow	(2.88)	1.35	1.11	0.94	0.93	0.91	0.88	0.88	0.88
IRR (% age)	33.80%								
NPV ` (in lakh)	2.53								

**Break Even Point**

` (in lakh)

<b>Particulars / Years</b>	<b>1</b>	<b>2</b>	<b>3</b>	<b>4</b>	<b>5</b>	<b>6</b>	<b>7</b>	<b>8</b>
<b>Variable Expenses</b>								
Oper. & Maintenance Exp (75%)	0.04	0.05	0.05	0.05	0.05	0.06	0.06	0.06
Sub Total(G)	0.04	0.05	0.05	0.05	0.05	0.06	0.06	0.06
<b>Fixed Expenses</b>								
Oper. & Maintenance Exp	0.01	0.02	0.02	0.02	0.02	0.02	0.02	0.02
Interest on Term Loan	0.25	0.19	0.17	0.13	0.07	0.01	0.00	0.00
Depreciation (H)	0.15	0.15	0.15	0.15	0.15	0.15	0.15	0.15
Sub Total (I)	0.42	0.36	0.34	0.29	0.24	0.18	0.17	0.17
Sales (J)	1.41	1.41	1.41	1.41	1.41	1.41	1.41	1.41
Contribution (K)	1.36	1.36	1.36	1.36	1.36	1.35	1.35	1.35
Break Even Point (L= G/I)%	30.53%	26.44%	24.70%	21.71%	17.94%	13.38%	12.69%	12.79%
Cash Break Even {(I)-(H)}%	19.39%	15.28%	13.52%	10.52%	6.72%	2.14%	1.43%	1.50%
Break Even Sales (J)*(L)	0.43	0.37	0.35	0.31	0.25	0.19	0.18	0.18

**Return on Investment**

` (In lakh)

<b>Particulars / Years</b>	<b>1</b>	<b>2</b>	<b>3</b>	<b>4</b>	<b>5</b>	<b>6</b>	<b>7</b>	<b>8</b>	<b>Total</b>
Net Profit Before Taxes	0.95	1.00	1.02	1.06	1.11	1.17	1.18	1.17	8.68
Net Worth	1.67	2.43	3.06	3.71	4.39	5.11	5.84	6.56	32.78
									26.47%

**Debt Service Coverage Ratio**

` (in lakh)

<b>Particulars / Years</b>	<b>1</b>	<b>2</b>	<b>3</b>	<b>4</b>	<b>5</b>	<b>6</b>	<b>7</b>	<b>8</b>	<b>Total</b>
<b>Cash Inflow</b>									
Profit after Tax	0.95	0.77	0.62	0.65	0.68	0.72	0.73	0.72	4.39
Depreciation	0.15	0.15	0.15	0.15	0.15	0.15	0.15	0.15	0.91
Interest on Term Loan	0.25	0.19	0.17	0.13	0.07	0.01	0.00	0.00	0.82
Total (M)	1.35	1.11	0.94	0.93	0.91	0.88	0.88	0.88	6.13

**DEBT**

Interest on Term Loan	0.25	0.19	0.17	0.13	0.07	0.01	0.00	0.00	0.82
Repayment of Term Loan	0.12	0.24	0.32	0.48	0.64	0.36	0.00	0.00	2.16
Total (N)	0.37	0.43	0.49	0.61	0.71	0.37	0.00	0.00	2.98
DSCR (M/N)	0.25	0.19	0.17	0.13	0.07	0.01	0.00	0.00	0.82
Average DSCR	2.06								



**Annexure 6: Procurement and implementation schedule**

No.	Activity Details	Days						
		2	4	6	8	10	13	15
1	Civil works							
2.	Fitment of Equipments							
3.	Trial Operation							
4.	Training to staff							

The total days for installation and commissioning of the equipments will take 45 days, out of which 30 days will take for the arrival of the equipment in the tea factory after placement of the order. After the arrival of the equipment the installation and commissioning break – up is as detailed;

- 2 days is considered for necessary documentation for service contract as per the conditions in the order and also verification of the specification as mentioned in the purchase order with that of the materials actually received.
- After formulation of the necessary documentation and after satisfaction regarding the material, the site selection will be done jointly along with the equipment supplier by the management representative of the tea factory. On the selected site necessary civil foundation and construction work will be carried out by the supplier in co – ordination with the factory personals. This is estimated to take 6 days after completion of activity 1.
- The fitment of equipments will take 4 days after the completion of the civil works.
- After completion of the installation, the equipment supplier will commission the equipment and as per the terms and conditions of MNRE, the equipment supplier will give a trial run for 3 days, i.e., 72 hours.
- Training to the staff will be provided simultaneously after activity till completion of the trial run.

**Annexure 7: Details of Technology Service Provider**

S. No.	Name of Service Provider	Address	Contact Person and No.
1.	Radiant Energy Service (Authorized agent of M/s HITA Technology (P) Ltd)	2nd floor, Lahkar Commercial Complex, (opposite Police Reserve); A T Road; Guwahati 781001	Deba Prasad Hazarika 098640 92040 Email: debaphazarika@gmail.com
2	Wind Turbine System (P) Ltd	478, 13th main, Koramangala 3rd block, Bangalore, , Karnataka India 560034	Telephone: 91-80-25539873 WebSite: <a href="http://www.wtswind.com">http://www.wtswind.com</a> E-mail: Send Email to Wind Turbine Systems (P), Ltd.
3	Trueskill Energen (P) Ltd	#125, 1st Main, Domlur 2nd Stage, , Bangalore, Karnataka India 560071	<ul style="list-style-type: none"> <li>• Telephone: +91 80 4125 6925</li> <li>• Web Site: <a href="http://www.energen.biz">http://www.energen.biz</a></li> <li>• E-mail: Send Email to Trueskill Energen Pvt Ltd</li> </ul>
4	Tachometric Controls	S. No. 50/10/12, Post. Narhe, , Pune, Maharashtra India 411041	<ul style="list-style-type: none"> <li>• Telephone: +91-20- 24391385</li> <li>• FAX: +01-20-24391179</li> <li>• Web Site: <a href="http://www.tachometric.com">http://www.tachometric.com</a></li> <li>• E-mail: Send Email to Tachometric Controls</li> </ul>

Annexure 8: Quotations or Techno-commercial bids for new technology/equipment



Monday, April 11, 2011

To,  
M/s Radiant Energy Services,  
2<sup>nd</sup> floor, Lahkar Commercial Complex,  
A. T. Road, Guwahati – 781 001.

Kind Attn : Mr. Hazarika.

**Sub: Rate quotation for 2 KW, 3 KW & 5 KW Hybrid System**

**Ref: Your enquiry.**

Dear Sir,

This has reference to your mail for the enquiry of solar lighting system. We appreciate your interest for HiTA make Solar System and thank you for your enquiry.

We take the pleasure to inform you that we, **M/s. HiTA TECHNOLOGY PVT. LTD.**, the manufacturer of HiTA make UPS Systems ranging 0.5KVA to 800KVA and **SOLAR HYBRID SYSTEMS from 100 WATT to 25 MW**, operating in India since 1997 are responsible for all kinds of activities and after sales service in **SAARC countries - India, Sri Lanka, Nepal, Bangladesh, Bhutan and Myanmar** for the entire range of products from HiTA.. As a mark of our quality, we have the privilege of being the first solar company in India to receive the **ISO 9001** accreditation.

Please find enclosed the bill of materials, system layout, Price Schedule and terms of supply for your kind perusal. We sincerely hope that you will find our offer is in line with your requirements.

Thanking you.

Yours faithfully,  
**For HiTA Technology Pvt Ltd.**

**Arun Das Ghosh.**  
**Managing Director.**

**2 KW SOLAR HYBRID SYSTEM - OFF-GRID POWER SYSTEM :-**

2 KW	SOLAR PANEL (Include Braket)	175 W ( 24V )	6 PCS	
	1 KW Wind Turbine			
	Control System		1 SET	
	Controller	2 KW	1 SET	
	Connector		As Required	<b>2,75,000.00</b>
BATTERY BACKUP FOR 14 HRS BACKUP				<b>1,40,000.00</b>
SUB TOTAL (A) :-				<b>4,15,000.00</b>
VAT / CST @ 4%				<b>16,600.00</b>
TOTAL VALUE FOR 2 KW SYSTEM				<b>4,31,600.00</b>

**3 KW SOLAR HYBRID SYSTEM - OFF-GRID POWER SYSTEM :-**

3 KW	SOLAR PANEL (Include Braket)	175 W ( 24V )	8 PCS	
	2 KW Wind Turbine			
	Control System		1 SET	
	Controller	3 KW	1 SET	
	Connector		As Required	<b>3,45,000.00</b>
BATTERY BACKUP FOR 14 HRS BACKUP				<b>2,20,000.00</b>
SUB TOTAL (A) :-				<b>5,65,000.00</b>
VAT / CST @ 4%				<b>22,600.00</b>
TOTAL VALUE FOR 3 KW SYSTEM				<b>5,87,600.00</b>

**5 KW SOLAR HYBRID SYSTEM - OFF-GRID POWER SYSTEM :-**

5 KW	SOLAR PANEL (Include Braket)	175 W ( 24V )	16 PCS	
	2 KW Wind Turbine			
	Control System		1 SET	
	Controller	5 KW	1 SET	
	Connector		As Required	<b>5,55,000.00</b>
BATTERY BACKUP FOR 14 HRS BACKUP				<b>3,85,000.00</b>
SUB TOTAL (A) :-				<b>9,40,000.00</b>
VAT / CST @ 4%				<b>37,600.00</b>
TOTAL VALUE FOR 5 KW SYSTEM				<b>9,77,600.00</b>

**The Above Price applicable only for Close Weathering Turf for ASSAM.**

**2. PV Module**

- 1)Power : 175W
- 2)Measurement : 1580\*808\*45mm
- 3)Open circuit voltage : 43.6v
- 4)Max Power : 35.71v
- 5)Short Circuit Current : 5.5A
- 6) Connection instruction

**Commercial Terms & conditions: -**

- 1 **Price :** Price quoted above is the basic price of the equipment F.O.R Destination.
- 2 **Packing & Forwarding :** Above quoted price are inclusive of Packing, Forwarding and other expenses.
- 3 **Sales Tax :** 4% VAT / CST will charge extra without "C" form.
- 4 **Installation & Commissioning Charge :** Above quoted prices are inclusive of Installation, Supervision of Erection & Commissioning. The lifting, shifting, civil job & cable laying is not our scope of supply.
- 5 **Delivery :** Delivery With in 3 to 6 weeks after receipt of technically and commercially clear purchase order.
- 6 **Warranty :** 24 months from the date of Installation/Commissioning including battery.
- 7 **Payment Terms :** 50% Advance along with the order and rest 50% with in 7 days from the date satisfactory receipts of the material at site.
- 8 **Other Charges :** Octroi, Entry Tax will be charged extra at actual, in case it is applicable. Road permit to be provided by you if applicable.
- 9 **Validity :** Validity 30 days from the date of this offer.

We hope the above is in line with your requirement, however, please contact us for further queries and / or clarifications if any.

Thanking you, assuring you of our best of services and looking forward to your valued order at an early date, we remain,

Yours faithfully,

For **Hita Technology Pvt. Ltd**

**Subhrajit Nandy**

09903995781

Asst. Manager - Logistic

## Annexure 9: MNRE Subsidy Document

The Project has been found Eligible to fetch subsidy of ` 1lakh per kW generated (given at page no. 47and table at annexure ii of the document).

No. 23/1/2009/SWES  
Government of India  
Ministry of New and Renewable Energy  
Small Wind Energy and Hybrid Systems Programme

Block No. 14, C.G.O. Complex,  
Lodi Road, New Delhi- 110 001

Dated: 16.04.2010

To  
Head, State Nodal Department /  
State Nodal Agencies (SNA's) /  
Other concerned Implementing Agencies

Sub: Modified scheme for the programme on "Small Wind Energy and Hybrid Systems(SWES)" during 2010-11 and 2011-12- reg.

I am directed to convey the sanction of the President of India for implementation of the programme on "Small Wind Energy and Hybrid Systems" during the last two years of the 11<sup>th</sup> Plan i.e. years 2010-11 and 2011-12. The detailed guidelines for implementation of the programme are given as Annexure - I.

### 2.0 Objective

The objective of the programme on "Small Wind Energy and Hybrid Systems" is to develop technology and promote applications of water pumping windmills and aerogenerators/wind-solar hybrid systems.

### 3.0 Programme Activities

The programme will support the following activities:

- Financial support for setting up water pumping wind mills and aerogenerators/wind solar hybrid systems,
- Field trials & performance evaluation,
- Grid connected SWES on demonstration basis,
- Research & Development.

### 4.0 Implementation

4.1 Various activities of programme on "Small Wind Energy and Hybrid Systems" will be implemented in association with the State Nodal Agencies (SNAs), manufacturers of SWESs, R&D/ academic/ autonomous institutions, NGOs, Govt. undertakings, and user organizations. The programme on wind solar hybrid systems is also aimed to be implemented in market mode through active involvement of manufacturers of SWESs.

### 5.0 Targets

Following annual targets for the years 2010-11 and 2011-12 have been fixed:

**5.1 Physical:** Water pumping windmills – 25 nos.  
Aerogenerator/wind-solar hybrid systems - 500 kW

**5.2 Financial:** Budget Estimate: Rs. 5.00 crores.

### **6.0 Central Financial Assistance (CFA) and Release of funds**

Central Financial Assistance (CFA) will be provided under the programme as per details given in Annexure - II and funds will be released as per Annexure - III.

### **7.0 Monitoring Arrangements**

- i) Monitoring of project implementation will be carried out through review meetings, field visits, etc. by MNRE.
- ii) Performance monitoring will also be carried out through SNAs and manufacturers. They are advised to set up suitable monitoring arrangements to closely monitor implementation of the programme, performance of the systems installed, and to send reports to MNRE, as per details given in para 13.0 of Annexure-I.
- iii) MNRE may also sponsor independent study on evaluation of the systems installed under the programme for which financial support may be provided on case to case basis from the budget allocation under the scheme .

### **8.0 Demonstration Projects in N-E, J&K areas**

25 SWES projects will be taken up in special areas in N-E including Sikkim and J&K including Leh and Laddakh having capacity in the range of 10 kW on demonstration basis with higher financial support. If required, suitable consultant will be engaged for preparing Detailed Project Report for implementation of these projects.

### **9.0 Other Activities :**

**9.1** Various organizations will be involved in organizing awareness, training, demonstration, seminars/workshops survey/assessment studies, preparation of DPRs for mini-grid concept etc. Further, Ministry may also directly sponsor training & awareness programme through selected institutions.

**9.2** GPRS/SCADA/Broad-band/other such technologies based system will be taken up for monitoring of the SWES systems on demonstration basis at five locations

**9.3** Demonstration projects of SWES will be taken up in a grid-connected mode/mini-grid concept to understand the viability and technical constraints/remedial actions etc. of these systems in grid-connected mode.

**10.0** The proposals for CFA will be considered based on technical viability and availability of funds within overall targets for the programme. The decision of the Secretary, MNRE will be final & binding in this regard.

This issues in exercise of the powers delegated to the Ministries and with the concurrence of IFD, MNRE vide their diary no. IFD-2390-09 dated 23.03.2010.

Yours faithfully,

-sd-

**(Dilip Nigam)**  
Director

**Copy for information and necessary action to:**

1. The Principal Director of Audit, Scientific Departments, DGACR Building, I.P. Estate, New Delhi – 110 002.
2. Chief Executives/Directors of all the State Nodal Agencies/ Corporations/ other Organizations implementing the MNRE programme
3. All Regional Offices of the Ministry of New & Renewable Energy.
4. All the existing manufacturers of the SWESs
5. SPO to Secretary, MNRE
6. AS&FA /All Advisors/JS (GS)/JS(HK)
7. Dir (F)/Dir (DN)/Dir(GU)
8. Individual files of all implementing agencies
9. Sanction folder
10. Guard file

-sd-  
**(Dilip Nigam)**  
Director



**Annexure I****Guidelines for Implementation of the Programme on “Small Wind Energy and Hybrid Systems”****1.0 System Applications**

The programme will support deployment of water pumping windmills (wind pumps) and small aerogenerators/ wind-solar hybrid systems for water pumping applications and generation of electricity in off-grid mode, respectively. Grid connected wind solar hybrid systems may also be taken up for demonstration purpose if state regulatory and other related issues are favorable. GPRS/ SCADA/ Broad – band/ other such technology based systems to be used for remote monitoring of SWES systems on demonstrations basis.

**2.0 Eligible Users**

All categories of users including individuals, farmers, NGOs, Central / State Government agencies, local bodies and Panchayats, Autonomous Institutions, Research Organizations, Cooperative Societies, Corporate Bodies, Business Establishments, Banks, etc. are eligible for having the systems installed for their use.

**3.0 Technical Specifications****3.1 Water Pumping Windmills**

Broad technical specification and other details of the water pumping windmills being promoted under the programme are given below. However, other models can also be considered based on their quality and performance.

Designs/ models	Broad technical specifications	Estimated Water output versus head	Suitability
Direct drive windmill such as 12 PU 500 and similar other windmills	Rotor diameter – 5 m Nos. of blades – 12 Tower height – 7 m Pump diameter – 150 mm Cut In wind speed – 10 km/hr Rated wind speed – 18 km/hr	8000 liters per hour at 7 meter head	For shallow water pumping upto 15 meter head
Gear type windmills	Rotor diameter – 3.3 m Nos. of blades – 18 Tower height – 10 m Pump diameter – 50-100 mm Cut In wind speed – 9 km/hr Rated wind speed – 18 km/hr	1000 liters per hour at 20 meter head	For deep well pumping from 10 meter to 60 meter head
AV 55 Auroville direct drive windmills	Rotor diameter – 5.7 m Nos. of blades – 24 Tower height – 9-23 m Pump diameter – 64-160 mm Cut In wind speed – 10 km/hr Rated wind speed – 18 km/hr	4000 liters per hour at 15 meter head	For shallow and deep well pumping upto 60 meter head

### 3.2 Aerogenerators

The rated capacity of individual aerogenerators covered under the programme will be up to a maximum of 100kW, however, MNRE support for installation of aerogenerators will be restricted to a maximum total capacity of 10 kW (project capacity). Both imported & indigenously manufactured/assembled aerogenerators are covered under the programme. The manufacturers will have to get their models empanelled with MNRE based on the testing/certification as per IEC 61400-2 and IEC 61400-12-1 for Design requirement and Power Performance and Safety function test as per the empanelment procedure evolved by the Centre for Wind Energy technology (C-WET), Chennai. A detailed empanelment procedure has been evolved by C-WET in consultation with all the stakeholders and is summarized at Para 6.2.

Only the MNRE empanelled models of the aerogenerators will be eligible for financial support under the scheme.

### 3.3 Hybrid Systems

Hybrid systems based on a combination of various renewable energy sources like wind and solar photovoltaic are covered under the scheme. The hybrid systems will be designed to meet the annual load requirement with optimum use of resources. The rated capacity of individual aerogenerator covered under the program will be upto a maximum of 100kW, however, MNRE support for installation of a Wind–Solar Hybrid system will be restricted to a maximum capacity of 50kW (system capacity). The wind component of the hybrid system has to be at least 60% of the total capacity. As mentioned above, only the MNRE empanelled models of the aerogenerators will be eligible to be used in Hybrid systems for financial support under the present scheme. The SPV modules to be deployed under the Programme should conform to the relevant IEC Standards. The SPV modules to be deployed under the Programme should conform to the relevant IEC Standards.

### 4.0 Site Selection

Selection of suitable sites for installation of small wind energy and hybrid systems will be the responsibility of the implementing agency i.e. manufacturers, State Nodal Agencies (SNA) or any other such agency. The broad guidelines for site selection are given below:

#### 4.1 Water pumping windmills

- (i) The site should be free from the obstacles like tall trees, high buildings, electric transmission lines etc. within the radius of about 100 meters.
- (ii) The site should have annual average wind speed more than 10 kmph.
- (iii) The designs/ models of water pumping windmills should be selected in accordance with their suitability for water table depths prevailing at the sites, as given in para 3.0 of technical specification of the windmills.
- (iv) The foundations should be designed and constructed by taking into consideration the soil bearing capacity of the site.
- (v) Recharging capacity of bore well or open well should be around 30 m<sup>3</sup>/hr.
- (vi) The windmills should be preferably installed in clusters to enable effective repair and maintenance services and to have better demonstration effect.

- (vii) The provision of a storage tank of suitable capacity should be mandatory to ensure supply of water during non-windy periods.

#### **4.2 Aerogenerators/ Wind-Solar Hybrid Systems**

- (i) The site should be free from the obstacles like tall trees, high buildings, electric transmission lines etc. within the radius of about 100 meters.
- (ii) The site for installation of aerogenerators should, preferably, have annual average wind speed of about 15 kmph (4.17 m/s) or above, at 20 m height. The wind speed at a particular site has to be obtained from C-WET or any other agency using actual wind data collected by C-WET or by using standard software programme like Wind Atlas etc. The user agency/manufacturer has to provide latitude-longitude of the site and other parameters as needed for this purpose to the verifying agency.
- (iii) Wind and solar resources should be preferably of complimentary nature.
- (iv) The foundations should be designed and constructed by taking into consideration the soil bearing capacity of the site.
- (v) Generally aerogenerators should be avoided to be installed on the roof of a building and if it is installed on the roof of any building, the load bearing capacity, clearance/obstruction from the nearby buildings, electrical wires etc. and other safety related aspects should be carefully examined by technical personnel.

#### **5.0 Eligible Manufacturers/ Suppliers**

##### **5.1 Water pumping windmills**

The manufacturers/suppliers whose windmills conform to the broad technical specifications, which have already been installed under this Ministry's programme, are eligible to manufacture, supply and install the windmills. A list of such manufacturers is given in **Annexure IV**

##### **5.2 Aerogenerators/ Wind-Solar Hybrid Systems**

Ministry has so far not been insisting for testing and certification of the aerogenerators. The present procedure for empanelment involves furnishing of information by the manufacturers about their company etc. through SNAs. It has been felt that the quality of systems being manufactured, supplied and installed under the MNRE programme is not of very high standards and, therefore, a new method has been evolved for empanelment of manufacturers/suppliers having quality products with Type Testing reports. A list of such eligible manufacture will be issued by the Ministry from time to time.

#### **6.0 Empanelment of manufacturers**

##### **6.1 Water Pumping Windmills**

The interested manufacturers/suppliers of water pumping windmills may provide detailed information about their firm, product and test report by independent test agency, confirming that the proposed design of the systems is in accordance with the broad technical specifications and performance characteristic, being claimed by themselves. They may submit their proposals to MNRE through SNAs providing all relevant details, as per the format given in **Annexure- V** for empanelment with MNRE.

## 6.2 Aerogenerators/Wind-Solar Hybrid Systems

C-WET in consultation with manufacturers has devised a scheme for empanelment, which seeks information from manufacturers on registration certificate of company showing legal identity of the company; adequate manufacturing facility; ISO 9001 requirements; simplified technical specification of the turbine; product manual covering details of installation, maintenance, routine inspection and personnel safety etc.; minimum simplified design documents; detailed electrical circuit diagrams; details of number of installations and its performance as per the formats provided by C-WET. The manufactures have to obtain a valid Type Test report for every model. If a valid Type Test Report is not already available with the manufacturer, they will enter into an agreement for Type Testing with C-WET or any other foreign/Indian recognized laboratory as per the IEC stipulations. In case the manufacture already has Type Test report form a recognized laboratory other than C-WET, it need to be submitted to C-WET & get it endorsed by them.

Based on the evaluation of the above details, the particular model of the manufacturer will be recommended by C-WET for empanelment. In case a valid Type Test report is not already available, a provisional empanelment will be granted initially for a period of one year, subject to the results of the Type Testing of machine by C-WET. Projects having systems from empanelled manufactures only will be eligible. Ministry will issue such list from time to time.

The manufacturers are required to contact C-WET for empanelment under intimation to the Ministry.

### 6.2.1 Dealers of the manufacturers

The empanelled manufacturers may also have their dealers. The dealers will register themselves with the State Nodal Agency (SNA) of the state, they want to operate. They may be registered with more than one state. The dealership letter from the main manufacturer with all its terms and conditions will be a pre-requisite. The SNAs may evolve a system to register a dealer of an MNRE empanelled manufacturer based on the Guidelines mentioned above. The dealers must have necessary capability to take-up the operation, repairs & maintenance of the system. In this case, the operation, repair and maintenance will be the responsibility of main manufacturer through their dealer. The main manufacturer will submit an undertaking in this regard. MNRE empanelled manufacturers will also be deemed registered with all SNAs to operate in a particular state. Ministry will issue such list from time to time.

## 7.0 Demonstration Projects in N-E, J&K areas

There is lot of potential and utility of Wind-solar hybrid systems in remote locations such as districts on international borders, North-Eastern States including Sikkim, Jammu & Kashmir including Leh & Laddakh at various institutions/organizations and defence/para-military establishments in these areas. 25 SWES projects will be taken up in these areas, as special projects, having capacity in the range of 10 kW on demonstration basis with Central Financial Assistance @ Rs. 2.25 lakh / kW. The balance cost including the cost towards transportation, installation, commissioning and distribution lines would be borne by the concerned beneficiary organizations. If required, suitable Consultants may be engaged for preparing Detailed Project Report for implementation of these projects.

## 8.0 Other Activities :

8.1 The SNAs, NGOs, technical organizations, Govt. undertakings, manufacturers and user organizations etc. will be involved in organizing awareness, training, demonstration, seminars/workshops survey/assessment studies, preparation of DPRs for mini-grid concept etc. Proposals in this regard will be considered for financial support on case to case basis. Further, Ministry may also directly sponsor training & awareness programme through selected institutions.

### On-line performance monitoring system

8.2 As per the existing provisions, the project beneficiaries and SNAs are to submit a periodic performance report of the systems. However it is not being received very regularly. It is desirable that GPRS or SCADA or Broad-band based system may be incorporated in every SWES system to access the generation data through PC or even on a Mobile phone. 5 existing SWES systems may be provided with such systems on demonstration basis with MNRE support. The CFA for this purpose may be decided on case to case basis.

### Grid-connected SWES systems

8.3 It has been decided to take up demonstration projects of SWES in a grid-connected/mini-grid concept to understand the viability and technical constraints/remedial actions etc. of these systems in grid-connected mode. MNRE support for such projects may be as per the provisions of the Technology Demonstration Scheme under the R&D Division of the Ministry (50% cost sharing basis). A monitoring system as mentioned above may also be a part of grid-connected systems.

## 9.0 Warranty

- (i) A warranty for a minimum period of two years from the date of installation of the wind pumps, small aerogenerator systems and hybrid systems will be provided by their respective manufacturers to the user/SNAs against any manufacturing defect and deficiencies in the design, engineering and materials of the components used in the system.
- (ii) The warranty will be applicable on entire system including batteries, electronics, mechanical supports etc.
- (iii) Solar PV modules used in the hybrid system will be warranted for a period of at least 10 years from the date of installation.
- (iv) The beneficiary will be responsible for periodical cleaning of solar panels, water topping of batteries, and cleaning of dusting of all electronic components and cabling etc.

## 10.0 Repairs and Maintenance

- (i) The manufacturers/suppliers are required to provide "on-site" training to the users in O&M of the systems, and equip them to attend to the minor repair themselves. (A certificate from the beneficiary/SNA/ implementing agency to this effect shall be provided by the supplier/manufacturer along with the commissioning/completion report to the ministry)

- (ii) The beneficiary will award annual maintenance contract (AMC) of at least 3 years, after the expiry of the warranty period. It shall be mandatory on the part of supplier/manufacturer to provide AMC for at least 3 years after warranty period at a reasonable cost to the beneficiary.
- (iii) Necessary maintenance spares for 3 years trouble-free operation will be supplied by the respective manufacturers/ suppliers of the systems.

## 11.0 Scope of Supply

### 11.1 Water Pumping Windmills (Wind Pumps)

The scope of supply will cover the design, manufacture, testing, supply, transportation, installation commissioning and performance monitoring of the complete water pumping windmills (comprising rotor, transmission, security mechanism, pump, tower, GI delivery pipe of suitable diameter and length, mandatory spares for three years trouble free operation, as identified by the manufacturer before supply) and user's tools & tackles kit. The manufacturer/suppliers of water pumping windmills will also supply a copy of a comprehensive manual to the user providing information on O&M and the recommended Dos and Don'ts for trouble free operation of the system.

### 11.2 Aerogenerators and Wind-Solar Hybrid Systems

The scope of supply of aerogenerators/wind-solar hybrid systems will cover the design of system-configuration, manufacture/supply, testing, transportation, installation, commissioning and performance monitoring of the complete system comprising aerogenerator, SPV modules, batteries, inverters, control systems, tower, cables, necessary instrumentation for monitoring of the field performance etc. The manufacturers/supplier will also supply spares for three year trouble free operation, user's tools & tackles kit, and a copy of comprehensive users manual providing information on performance data, power curve, O&M and recommended Dos and Don'ts for trouble free operation of the system. It has been noted that the suppliers do not take care of repair/maintenance of the systems. Both the parties should, therefore, make necessary provision in the Contract at the time of award of work so that trouble free operation of the system is ensured. The critical spare parts like inverter card etc. must be supplied by manufacture at the time of commissioning so that uninterrupted functioning of the system takes place.

### Installation of Energy Meters

It has been noted that energy meter is installed only for the energy consumed from the systems by the load i.e. after the storage system(Battery). This does not give the information about the total energy generated by the system. It is therefore decided that one additional energy meter will be installed which will measure the total energy generated by the system.

### Unique Identification Number (UIN)

It has been decided to introduce a Unique Identification Number (UIN) to be put on every aerogenerator. Every manufacturer will have a UIN for every aerogenerator having

five alphabets and ten digits (e.g. UD/MAH/0001/241209) as per following structure to be issued to every aerogenerator and clearly and visibly displayed by painting it vertically on the pole of the aerogenerator.

- First two alphabets : Indicating manufacturer's name (viz. UD,UE)
- Next three alphabets : Indicating State's name where it is installed (viz. Mah, Goa)
- Next four digits : Indicating serial number of the machine supplied by the manufacturer starting with 0001 (to begin with effect from issue of this scheme)
- Next six digits : Indicating date of commissioning (day-month- year)

## 12.0 Submission of Proposals and Project Implementation

### 12.1 Water Pumping Windmills (Wind Pumps)

- (i) Proposals for installation of water pumping windmills will be taken up on project-to-project basis received from State Nodal Agencies (SNAs).
- (ii) Proposals must accompany commitment of SNAs / each beneficiary for meeting the remaining part of the project cost other than MNRE's CFA.
- (iii) The SNAs will submit proposals as per the format given at **Annexure - VI**
- (iv) After sanction of the projects by MNRE, the SNAs will complete the process of awarding the work for manufacture, supply, installation and post installation services of water pumping windmills within 4 months from the date of sanction, and submit the copy of work order (s) and acceptance of manufacturer (s) to MNRE for release of first installment of CFA.
- (v) During project implementation, the SNAs will ensure, through regular field visits, physical verification, and enforcing such terms and conditions that the quality-standards are maintained by the manufacturers/suppliers during manufacturing, supply, installation and handing over of the system to beneficiaries.
- (vi) The SNAs will obtain feedback on performance/functioning of windmills regularly through their field visits, etc., and send the same to MNRE quarterly.
- (vii) The SNAs will arrange for immediate repair of the system, in the event of its major break down, through manufacturers/ suppliers.
- (viii) The SNAs will ensure that the project is completed within 9 months after placing the work order (s) and acceptance by supplier (s).

### 12.2 Aerogenerators and Wind-Solar Hybrid Systems

- (i) SNAs/manufacturers/beneficiaries may send bundled proposals alongwith Feasibility reports for deployment of the system in a "Project Mode" for different users such as Tribal Hostels, Primary Health Care Centers, Nursing homes Police Communication Centers, Anganwadis, Literacy Centers, Panchayati Raj Institutions including private individuals & corporate sector etc. In a bundled proposal, separate feasibility reports have to be submitted for separate projects/sites.
- (ii) Proposals must accompany a written commitment of SNAs /other government bodies/ each beneficiary for meeting the remaining part of the project cost other than MNRE's CFA.
- (iii) The manufacturers/SNAs will get prepared a feasibility report providing information as per Annexure – VII and after verifying the suitability of the site

and system based on site visits considering the load requirements. The manufacturers/SNAs will submit the proposals to MNRE along with feasibility report.

- (iv) The feasibility report will provide all technical details of aerogenerator, solar PV modules, batteries, inverter, control system, cables and tower etc. and other components covered under the project. In the case of battery storage, only tubular plate lead acid batteries will be permitted.
- (v) There could be following modes of submitting the proposal to MNRE :

**(A) Implementation through Manufacturers**

The manufacturers will identify suitable beneficiaries, prepare a bundled proposal having a minimum cumulative capacity of 30 kW and a minimum number of 3 systems and submit to MNRE. Proposal with higher capacity (30 kW or more) with single beneficiary can also be considered. After examining the proposal, the Ministry will issue an "in principle approval" indicating the amount of subsidy for the project. The beneficiary in this route will necessarily have to go for financing through banks/financial institutions for meeting full/part of the cost of the project. The eligible subsidy would be released after the concerned manufacturer obtains the necessary documents regarding project completion report as per Annexure VIII and Project Monitoring report for at least three months period of the system as per the format given at Annexure IX from the Bank/Financial Institution and submits the same to the Ministry. The manufacturer will also ensure submission of quarterly monitoring reports as per the Annexure IX for at least one year of the operation.

**(B) Implementation through SNAs**

The State Nodal Agencies could also submit proposals on a project mode to the Ministry (bundled proposal having a minimum cumulative capacity of 30 kW and a minimum number of 3 systems; proposal with higher capacity (30 kW or more) with single beneficiary can also be considered). In this case also, the Ministry would issue an approval in principle for the eligible subsidy. The eligible subsidy will be released to the SNA for onward transmission to the concerned beneficiary after commissioning of the system and receipt of the prescribed documents regarding project completion report as per Annexure VIII and Project Monitoring report for at least three months period of the system as per the format given at Annexure IX . The SNA will also ensure submission of quarterly monitoring reports as per the Annexure IX for at least one year of the operation. The stipulation contained in the earlier scheme to provide work order by the State Nodal Agencies based on a competitive tender procedure will not be required as the beneficiaries/beneficiary institutions will be free to select the system from the list of the empanelled manufacturers following their own purchase procedure.

An administrative charges @ 2% of CFA will be provided to SNAs at the time of final release.



(C ) The manufacturers may also bundle the proposals for beneficiaries, who do not wish to avail the Bank Loan and submit to Ministry through SNAs ( with an advance copy to Ministry). The SNAs may forward the same to Ministry. The Ministry may consider issuing an approval in principle for the proposal, for such cases even if the SNA does not forward it after a reasonable time. The subsidy will be released to the Bank Account of the beneficiary after commissioning of the system and based on documents regarding project completion report as per Annexure VIII and Project Monitoring report for at least three months period of the system as per the format given at Annexure IX by a Designated Agency (DA) including the SNAs. The Ministry will empanel the Designated Agency in due course and suitable service charges will be paid to the services of such DA. The DA will also ensure submission of quarterly monitoring reports as per the Annexure IX for at least one year of the operation.

(D) Ministry may also consider the proposals in "Project Mode" directly from Govt. organizations based on the above mentioned modalities.

- (vi) In all above cases, the manufacturers/SNAs/beneficiary will complete the project within one year after in principle sanction of the project is issued by MNRE.

#### **13.0 Submission of quarterly monitoring reports, completion reports, audited Statements of Accounts**

- (i) After completion of the projects, the SNAs/manufacturers/DA/other implementing agency are required to submit project monitoring reports to MNRE as per the format given in Annexure IX on quarterly basis for at least one year. The manufacturers/SNAs/DAs/other implementing agencies are also requested to inform MNRE about difficulties, if any, faced by them and the proposed corrective actions.
- (ii) The SNAs/manufacturers will also submit an audited statement of expenditure on entire project cost by the user as per format given in Annexure - XI.

#### **14.0 Field Trials and Performance Evaluation of New designs/developments and proto types**

Field trials and performance evaluation of new designs of wind pumps, small aerogenerator systems, hybrid systems and their sub systems, parts, components used in such systems and proto-types when developed under a R&D project or independently developed by a manufacturer through its own R&D efforts will be fully supported financially by the Ministry. Field trials and evaluation of such new developments will be fully supported by the Ministry in a project mode meeting all costs relevant to the project. In case of systems/components developed by industry through their own R&D, the Ministry will meet the cost of the small wind energy system and cost of the relevant monitoring equipment and other expenses relating to the monitoring of the system. The remaining cost of the project will be met by the user organization. A maximum of 5 units of a system/sub system/ proto type may be tried out under this arrangement in a year.

**Pattern of Central Financial Assistance (CFA)****1. Water Pumping Windmills (Wind Pumps)**

- (a) The MNRE will meet up to 50% of the ex-works cost of water pumping windmills, except for unelectrified islands & North eastern States including Sikkim for which up to 90% of the ex-works cost, subject to the following upper ceilings for each approved design of the windmill (wind pump):

Type of Windmill	Maximum MNRE support	
	General Area	Island
(1) Direct drive gear-less windmills such as Modified 12 PU 500 and similar other Windmills	Rs.20,000/-	Rs.30,000/-
(2) Gear type windmill	Rs.30,000/-	Rs.50,000/-
(3) AV55 Auroville type windmill	Rs.45,000/-	Rs.80,000/-

(b) The Ministry will determine the CFA for other designs of water pumping windmills at the time of evaluation of the performance of the new model/design.

(c) The MNRE will provide administrative charges of 2,500 per windmill (wind pump) to the state agency.

**2. Aerogenerators/Wind-Solar Hybrid Systems**

- (a) The MNRE support for aerogenerators/wind solar hybrid systems will be provided on per kW basis. The support will be provided on the basis of type of users. Following two slabs of CFA will be available:

Govt./Public/Charitable, R&D, academic and other non-profit making institutions	Rs 1.50 Lakh per kW
Other beneficiaries not covered above (Individuals and private/ corporate sector will come under this category)	Rs 1.00 Lakh per kW

(b) The remaining cost of the system and all other expenditure related to packing & forwarding, transportation, installation and commissioning of the system will be a part of the system and will be met by the beneficiary of the system.

(c) In case of installation of systems to be done through SNAs, an administrative charge @ 2% of CFA will be provided to SNAs at the time of final release.

**3. Other Activities**

- a) For the purpose of organizing awareness, training, demonstration, seminars/workshops survey/assessment studies, preparation of DPRs for mini-grid concept etc, proposals for financial support will be considered on case to case basis.
- b) Financial support for 5 demonstration projects for monitoring of SWES with a GPRS/SCADA/ Broad-band/other such technologies based system may be provided on case to case basis.
- c) Demonstration projects of SWES in a grid-connected mode (mini-grid) will be taken up. MNRE support for such projects may be as per the provisions of the Technology Demonstration Scheme under the R&D division of the Ministry (50% cost sharing basis).
- d) Financial support will also be provided to take up R&D projects incorporating the possible improvements in the electronics and other components of wind solar hybrid system, particularly to make such systems workable in extreme and hazardous conditions.

**Annexure III**

**Release of Central Financial Assistance**

**I. Water pumping windmills**

- (a) 80% of the CFA, and 50% of service charges to SNAs on receipt of a copy of work order (s) along with its acceptance by the supplier (s) of the system (s), provided Utilization Certificates for the earlier years/releases have been submitted to the Ministry.
- (b) Remaining 20% of the CFA, and 50% of the service charges on physical verification of installation and commissioning of the systems by the SNAs as per DPR norms/approved project proposal, and submission of Project completion report; Utilization Certificates (Annexure – X), audited statement of expenditure Annexure-XI.
- (c) The SNAs will ensure that they have already sent the Utilization Certificates and audited consolidated statement of expenditure for the programme of previous years for settlement of accounts, before sending the request for release of the 20% CFA of the projects as mentioned in point '(b)' above. The MNRE will consider release of the funds only after receipt the above documents relating to the projects of the previous years.

**II. Aerogenerator/Wind-Solar Hybrid Systems**

- (a) No release will be made alongwith the in principle approval.
- (b) 100% CFA will be released after receipt of the required documents including project completion/commissioning certificate, performance monitoring certificate, audited statement of expenditure for the entire expenditure on the project as per the format given as Annexure XI.

**III. Other activities**

For all other activities under the programme, release pattern will be decided on case to case basis.

**Annexure IV****List of Eligible Manufacturers for Supply, Installation & Commissioning of Water Pumping Windmills (Wind Pumps)**

Sl. No.	Name & address	Tel No.	Fax No.	Type of windmill
1	Kamal Engineering Works, Bhatt Market Block 'C', Bharopar, Ramchandrapur, Biharsharif, Nalanda, Bihar			Modified 12 PU 500
2	Nalanda Engineering Works, Bhainsasoor, Ranchi Road, Biharsharif, Nalanda, Bihar			Modified 12 PU 500
3	Sarvodaya Engineering Works, Industrial Estate, Ramchandrapur, Opp. Ajanta Cinema, Biharsharif – 803 101 (Nalanda), Bihar	06112 - 222508		Modified 12 PU 500
4	Vikas Engineering Works, At & P.O. Mirchaiganj, Nalanda, Bihar			Modified 12 PU 500
5	Aureka, Aspiration Auroville, 605 101, Tamilnadu.	0413 – 2622278, 2622134, 2622651 <a href="mailto:aureka@auroville.org.in">aureka@auroville.org.in</a>	0413 - 2622274	AV 55 Auroville
6	Amey Industries, W-77, MIDC, Additional Industrial Area, Ambad – 422 010	0253 – 2381912, 6565903 <a href="mailto:mukundamey@rediffmail.com">mukundamey@rediffmail.com</a>	0253-2381912 2	Gear type
7	Om Engineering Works, Near Ganga Gate, Near Ambaji Temple, At & P.O. Anjar, District Kutch, Gujarat.			Gear type
8	Prototype Development Training Centre, Aji Industrial Estate, Bhavnagar Road, Rajkot, Gujarat.			Gear type
9	Rural Engineering School, At: Rojmal, Tal: Gadhada (Swa.), District Bhavnagar – 364 750, Gujarat	02847 – 294127 <a href="mailto:ruralschool@rediffmail.com">ruralschool@rediffmail.com</a>	02847 - 253535	Gear type
10	Scientific Instrument Co. Ltd. B-1 Site 2, Loni Road, Mohan Nagar, Ghaziabad – 201 007.	2732644 2732954 <a href="mailto:sicogzb@del3.vsnl.net.in">sicogzb@del3.vsnl.net.in</a>	2736235	Gear type
11	Wind Fab, 447 Avanashi Road, Peelamedu, Coimbatore-641004, Tamilnadu	0422 – 2572079		Gear type
12	Shreeji Agro Industries, At Post: Ramlechi, Ta. Talala (Gir) – 362 150 zdist. Junagadh, Gujarat	02877-222608 09925729186 (M) <a href="mailto:shreejiurja@yahoo.co.in">shreejiurja@yahoo.co.in</a>		Gear type

Annexure - V

**Format for empanelment of the manufacturers of water pumping windmills in MNRE**

The manufacturers will submit following information for empanelment :

- I. Technical specifications of water pumping windmill/ aerogenerator with testing report from independent testing agency/ foreign principals.
- II. Performance characteristics of water pumping windmill under different total pumping heads and varying wind speeds
- III. Performance curve of aerogenerator for its operating range of wind speed.
- IV. In case of technology transfer from abroad, copies of agreement/MOU entered into with foreign company / collaborator.
- V. Cost details of windmills/ aerogenerators.
- VI. Copy of registration as SSI unit/ SIA registration.
- VII. Details of infrastructure/ manufacturing/ assembly/ testing facilities/ marketing network/ arrangement for after sales support available with the company. Company to provide warranty details for the product.
- VIII. Copies of support documents indicating performance of the products.
- IX. Recommendation of state nodal agency on the following:
  - a) Infrastructure facilities available with the company.
  - b) Technical capabilities of the company.
  - c) Manufacturing / assembling/ testing facilities available with the company.
  - d) Marketing network of the company.
  - e) After sales support mechanism adopted by the company.
  - f) Over-all comment about accepting/ rejecting the proposal of the company.

Annexure - VI**Format for submission of project proposals by SNAs (for windmills)**

1. Name of State Nodal Agency:
2. No. of windmills proposed to be installed:
3. Type of windmills:
4. Site identification/selection: As per the Proforma enclosed (\*).
5. Project cost:
  - (ii) Total estimated ex-works cost of the windmills:
  - (iii) Total estimated ex-works cost of the windmills including transportation, installation, foundation, storage tank, insurance, etc.:
6. Cost sharing arrangements:
  - (i) Central Financial Assistance (CFA):
  - (ii) State Government share:
  - (iii) Beneficiaries' share:
7. Proposed Methodology of implementation:
8. Project duration (maximum 9 months):
9. Installation in cluster/dispersed mode:
10. Monitoring arrangements:
11. Post installation services/repair & maintenance arrangements proposed:

**(\*) Proforma for site selection**

Sl. No.	Name of beneficiary and site address	Amount of Beneficiaries contribution to be deposited with SNA	Water table depth	Type of water source (open/borewell/pond)	Annual average wind speed	Purpose of windmills (drinking water, minor irrigation, salt farming, etc.)	Type of windmill proposed	Provision of storage tank and capacity	Estimated cost of windmill	
									Ex-work cost	Total cost

**Annexure VII****Proforma for Feasibility Report for Aerogenerator/  
Wind Solar Hybrid Systems****1. Title of the project and the details of the project site:**

- Name of the organization:
- Address of site with Taluk/ district etc.
- Name of the contact person with telephone number, fax no. email etc.
- Type of establishment : Please provide brief details of the establishment.
- Category of the beneficiary : Profit making/ Not profit making

**2. Wind and Solar resources data of the identified site:**

Month	Air temperature	Daily solar radiation horizontal	Atmospheric pressure	Wind speed *	Heating degree-days	Cooling degree-days
	°C	KWh/m <sup>2</sup> /d	kPa	M/s	°C-d	°C-d
January						
February						
March						
April						
May						
June						
July						
August						
September						
October						
November						
December						
Annual						
Measured at (M agl)						

\* Please enclose the supporting details verifying the wind data (report by C-WET/ other institution)

**3. Estimated Energy Requirement at the proposed site:**

TYPE OF LOAD	USAGE TIME Hrs.	QTY.	PER DAY ENERGY REQUIREMENT (kWh)

**4. System Design Details.**

Battery Bank Total Energy Consumption /day Voltage configuration Power factor	
--	--

Battery efficiency Depth of discharge Battery capacity required	
Inverter Total Load Power factor Inverter efficiency Inverter capacity required	

5. Final design configuration of the \_\_\_\_\_ kW capacity wind-solar hybrid system:

a) Number, Capacity, specification and power curve of Aerogenerator proposed:

Aerogenerator Capacity Make & Model No. Type Test report available: Yes/No Does this model appear in MNRE empanel: Yes/No Rated wind speed Peak power Start generating wind speed Survival wind speed Propeller diameter Propeller material & No. of blades Generator Weight Voltage controller Over speed protection No. of machines	
--	--

b) Number & specification of SPV Modules

SPV Modules Capacity Make Peak power per module Weight Dimension W x H x D Temperature Wind Load Humidity No. of SPV Modules	
---	--

c) Details of various equipment/ sub-systems

d) Monitoring of system and spares.

6. Methodology of project implementation.



**7. Details of the estimated cost of the system:**

Sl. No.	Item	Cost (Rs. in lakhs)
1.	Aerogenerators	
2.	Photovoltaic Panels	
3.	Cabling from SPV module to control center and cabling from Aerogenerator to control center	
4.	Invertors *** KVS	
5.	Tower & Erection material	
6.	Batteries **v/** Ah	
7.	Photovoltaic Panels structure with fencing	
8.	Instrumentation (ammeter, voltmeter, energy meter, wind and solar monitoring equipment, Ah meter, battery level indicator)	
9.	Wind charge controller and solar photovoltaic charge controller	
10.	Ex-Work Cost Total (total of 1 to 9)	
11.	Transportation	
12.	System, Design, Erection, Testing, Commissioning	
13.	Civil Work	
14.	Total (total of 11 to 13)	
15.	Grand Total (10+14)	

**8. Proposed Sources of financial assistance.**

Sl. No.	Details	Cost (Rs. in lakhs)
(i)	MNRE support	
(i)	State govt subsidy, if any*	
(ii)	User share*	
	Total	

\* Please enclose the necessary letters from the supporting agency/user

**10. Project Implementation Schedule.**

The project implementation schedule to be given indicating different stages of implementation with dates. The project has to be completed within one year from date of sanction of the project by MNRE.



**PROFORMA FOR PROJECT COMPLETION REPORT OF AEROGENERATOR/WIND-  
SOLAR HYBRID SYSTEM**

1.	<b>System Details</b>	
	(a) MNRE Sanction No. and date:	
	(b) Capacity of the system (kW) Aerogenerator Component (kW) SPV Component (kW)	
	c) Name of Manufacturer/ Supplier	
	d) Commissioning Date	
	e) System's design (line sketch)	
	f) System's photograph (at least 5)	
2.	<b>Estimated Energy Requirement</b>	
	a) Type of Load	
	b) Usage time (Hours)	
	c) Quantity	
	d) Per Day Energy Requirement (kWh)	
3.	<b>Technical Details of the System Installed</b>	
	a) Aerogenerator Total capacity Capacity of single machine No. of machines Make & Model No. MNRE's reference number/ date of issue of inclusion in MNRE list Rated wind speed Rated Peak power UIN of each aerogenerator Generator Specification Voltage controller Over speed protection	
	b) SPV Modules Total capacity Capacity of each Module Nos. of SPV Modules Make Peak power per module Weight Dimension W x H x D Temperature Wind Load	
	c) Number and Place of Installation of Energy Meters	
	d) Battery Bank Total Energy Consumption /day Voltage configuration Power factor Battery efficiency Depth of discharge	

	Battery capacity required	
	e) Inverter Total Load Power factor Inverter efficiency Inverter capacity required	
	f) Balance of System (give details)	
	g) Details of spares provided	
4.	Training Details	
	a) Whether training provided by manufacturer/ Supplier to the user	Yes/No.
	b) Whether documents provided by manufacturer / Supplier to the user	Yes/No.
	c) Whether system is properly maintained by the user	Yes/No.
	d) Overall satisfaction of the user	

Signature \_\_\_\_\_  
 Name \_\_\_\_\_  
 Designation \_\_\_\_\_  
 Head of State Nodal Agency/ Manufacture  
 with seal  
 Date \_\_\_\_\_

Signature \_\_\_\_\_  
 Name \_\_\_\_\_  
 Designation \_\_\_\_\_  
 User Agency/ Beneficiary.  
 Date \_\_\_\_\_

Signature \_\_\_\_\_  
 Name \_\_\_\_\_  
 Designation \_\_\_\_\_  
 Bank or Financial Institution/Designated Agency  
 for monitoring with Seal  
 Date-----

**ANNEXURE-IX****PROFORMA FOR PROJECT MONITORING REPORT OF AEROGENERATOR/WIND-SOLAR HYBRID SYSTEM**

<b>1. System Details</b>						
(a) MNRE Sanction No. and date:						
(b) * Total Capacity of the system (kW) * Nos/unit capacity of aerogenerator * Total Aerogenerator Capacity (kW) * UINs of aerogenerator * Nos of module/unit capacity of a module * Total SPV Capacity (kW)						
c) Name of Manufacturer/ Supplier						
d) Commissioning Date						
<b>Performance Details</b>						
Month/Year	Aerogenerator		SPV		Total No. of Units (kWh) generated	Total No. of Units (kWh) consumed
	Average Wind Speed	No. of Units (KWh) generated	Average solar insolation	No. of Units (KWh) generated		
Are all the aerogenerators/SPV modules are functioning ?						
Whether system is properly maintained by the user						
Overall satisfaction of the user						
Satisfaction of Monitoring Team about the performance						
Any other information to be provided						

Signature \_\_\_\_\_  
 Name \_\_\_\_\_  
 Designation \_\_\_\_\_  
 Head of State Nodal Agency/ Manufacture  
 with seal  
 Date \_\_\_\_\_

Signature \_\_\_\_\_  
 Name \_\_\_\_\_  
 Designation \_\_\_\_\_  
 User Agency/ Beneficiary.  
 Date \_\_\_\_\_

Signature \_\_\_\_\_  
 Name \_\_\_\_\_  
 Designation \_\_\_\_\_  
 Bank or Financial Institution/Designated Agency  
 for monitoring with Seal  
 Date \_\_\_\_\_

**GRF 19-A**  
**[See Rule 212(1)]**

**Format of Utilization Certificate**

Sl. No.	Letter No. _____ and date _____	Amount
Total		

Certified that out of Rs. \_\_\_\_\_ of Grants-in-Aid sanctioned during the year \_\_\_\_\_ in favour of (Name of SNA) under this Ministry Department letter No. given in the margin and Rs. \_\_\_\_\_ on account of unspent balance of the previous year, a sum of Rs. \_\_\_\_\_ has been utilized for the purpose of (programmes Name) for which it was sanctioned and that the balance of Rs. \_\_\_\_\_ Remain un-utilized at the end of the year has been surrender to Government (Vide No.... dated.../ will be adjusted towards the Grants-in-aid payable during the next year.

2. Certified that I have satisfied myself that the conditions on which the Grants-in-aid was sanctioned have been duly fulfilled/ are being fulfilled and that I have exercised the following checks to see that the money was actually utilized for the purpose for which it was sanctioned.

Kinds of checks exercised.

- 1.
- 2.
- 3.
- 4.

Signature:

Name :

Designation of the head of the institutuion:

Dated:

**Annexure XI****Proforma for submitting the audited Statement of Expenditure****Statement of Expenditure**

( on the letter head of the Chartered accountant indicating his registration number)

MNRE Sanction No. .... dated .....

NAME OF THE PROJECT SITE :

System Details , capacity etc. :

Break-up of the total Expenditure on the project is as under:

Sl. No.	Item	Expenditure (Rs.)
Total		

This is to certify that a total expenditure of Rs.....has been made/is to be made on the project, out of which Rs.....has already been released to the manufacturer/supplier and remaining Rs.....will be released after receipt of the MNRE support. ( enclose supporting documents ).

Name and Signature of the Chartered Accountant with his seal



### **Bureau of Energy Efficiency (BEE)**

(Ministry of Power, Government of India)

4th Floor, Sewa Bhawan, R. K. Puram, New Delhi – 110066

Ph.: +91 – 11 – 26179699 (5 Lines), Fax: +91 – 11 – 26178352

Websites: [www.bee-india.nic.in](http://www.bee-india.nic.in), [www.energymanagertraining.com](http://www.energymanagertraining.com)



### **Petroleum Conservation & Research Association**

**Office Address :- Western Region**

C-5, Keshava Building, Bandra-Kurla Complex; Mumbai – 400051

Website: [www.pcra.org](http://www.pcra.org)



### **India SME Technology Services Ltd**

DFC Building, Plot No.37-38,

D-Block, Pankha Road,

Institutional Area, Janakpuri, New Delhi-110058

Tel: +91-11-28525534, Fax: +91-11-28525535

Website: [www.techsmall.com](http://www.techsmall.com)