

DETAILED PROJECT REPORT ON ENERGY EFFICIENT MOTOR FOR COMPRESSOR– 75HP (BHIMAVARAM ICE MAKING CLUSTER)



Bureau of Energy Efficiency

Prepared By



Reviewed By



ENERGY EFFICIENT MOTOR FOR COMPRESSOR -75HP

BHIMAVARAM ICE MAKING CLUSTER

BEE, 2010

Detailed Project Report on Energy Efficient Motor for Compressor
(75 HP)

Ice Plant SME Cluster, Bhimavaram, Andhra Pradesh (India)

New Delhi: Bureau of Energy Efficiency;

Detail Project Report No.: **BHIM/ICE/EEP/02**

For more information

Bureau of Energy Efficiency (BEE)
(Ministry of Power, Government of India)
4th Floor, Sewa Bhawan
R. K. Puram, New Delhi – 110066

Telephone +91-11-26179699

Fax+91-11-26178352

Websites: www.bee-india.nic.in

Email: [jsood@beenet.in/](mailto:jsood@beenet.in) pktiwari@beenet.in

Acknowledgement

We are sincerely thankful to the Bureau of Energy Efficiency, Ministry of Power, for giving us the opportunity to implement the BEE SME project in “Ice Making Cluster, Bhimavaram, West Godavari District of Andhra Pradesh”. We express our sincere gratitude to all concerned officials for their support and guidance during the conduct of this exercise.

Dr. Ajay Mathur, Director General, BEE

Smt. Abha Shukla, Secretary, BEE

Shri Jitendra Sood, Energy Economist, BEE

Shri Pawan Kumar Tiwari, Advisor (SME), BEE

Shri Rajeev Yadav, Project Economist, BEE

Andhra Pradesh Industrial & Technical Consultancy Organization Ltd. (APITCO) is also thankful to “*Ice Factory Owners Welfare Association, Bhimavaram, Warangal*” for their valuable inputs, co-operation, support and identification of the units for energy use and technology audit studies and facilitating the implementation of BEE SME program in Warangal Rice Milling Cluster.

We take this opportunity to express our appreciation for the excellent support provided by Ice making unit owners, local service providers, and equipment suppliers for their active involvement and their valuable inputs in making the program successful and in completion of the Detailed Project Report (DPR).

APITCO is also thankful to all the SME owners, plant in charges and all workers of the SME units for their support during the energy use and technology audit studies and in implementation of the project objectives.

APITCO Limited

Hyderabad

Contents

<i>List of Annexure</i>	<i>vii</i>
<i>List of Tables</i>	<i>vii</i>
<i>List of Figures</i>	<i>viii</i>
<i>List of Abbreviation</i>	<i>viii</i>
<i>Executive summary</i>	<i>ix</i>
<i>About BEE'S SME program</i>	<i>xi</i>
1 INTRODUCTION	1
1.1 Brief Introduction about cluster	1
1.1.1 Production process	1
1.2 Energy performance in existing situation	2
1.2.1 Fuel and electricity consumption of a typical unit in the cluster	2
1.2.2 Average production by a typical unit in the cluster	3
1.2.3 Specific Energy Consumption	3
1.3 Existing technology/equipment	3
1.3.1 Description of existing technology.....	3
1.3.2 Its role in the whole process	4
1.4 Establishing the baseline for the equipment.....	4
1.4.1 Design and operating parameters.....	4
1.4.2 Electricity consumption in existing system	4
1.4.2 Operating efficiency of the existing motor	5
1.5 Barriers for adoption of new and energy efficient technology / equipment.....	5
1.5.1 Technological Barriers	5
1.5.2 Financial Barrier.....	5
1.5.3 Skilled manpower	5
1.5.4 Other barrier(s)	6
2. TECHNOLOGY/EQUIPMENT FOR ENERGY EFFICIENCY IMPROVEMENTS.....	7
2.1 Detailed description of technology/equipment selected.....	7
2.1.1 Description of equipment	7

2.1.2	Technology /Equipment specifications	7
2.1.3	Justification of the technology selected & Suitability	8
2.1.4	Superiority over existing technology/equipment	8
2.1.5	Availability of the proposed technology/equipment.....	9
2.1.6	Source of technology/equipment for the project.....	9
2.1.7	Service/technology providers	9
2.1.8	Terms of sales	9
2.1.9	Process down time during implementation.....	9
2.2	Life cycle assessment and risks analysis.....	9
2.3	Suitable unit/plant size in terms of capacity/production	9
3.	ECONOMIC BENEFITS OF NEW ENERGY EFFICIENT TECHNOLOGY.....	10
3.1	Technical benefits.....	10
3.1.1	Fuel savings per year.....	10
3.1.2	Electricity savings per year	10
3.1.3	Improvement in product quality	10
3.1.4	Increase in production.....	10
3.1.5	Reduction in raw material consumption	10
3.1.6	Reduction in other losses.....	10
3.2	Monetary benefits	10
3.3	Social benefits	10
3.3.1	Improvement in working environment in the plant	10
3.3.2	Improvement in skill set of workers	10
3.4	Environmental benefits	11
3.4.1	Reduction in effluent generation	11
3.4.2	Reduction in GHG emission such as CO ₂ , NO _x , etc	11
3.4.3	Reduction in other emissions like SO _x	11
4.	INSTALLATION OF NEW ENERGY EFFICIENT MOTOR.....	12
4.1	Cost of technology/equipment implementation.....	12

4.1.1	Cost of technology/equipments.....	12
4.1.2	Other costs	12
4.2	Arrangement of funds	12
4.2.1	Entrepreneur's contribution.....	12
4.2.2	Loan amount.....	12
4.2.3	Terms & conditions of loan	12
4.3	Financial indicators	12
4.3.1	Cash flow analysis	12
4.3.2	Simple payback period.....	13
4.3.3	Net Present Value (NPV)	13
4.3.4	Internal rate of return (IRR).....	13
4.3.5	Return on investment (ROI)	13
4.4	Sensitivity analysis in realistic, pessimistic and optimistic scenarios	13
4.5	Procurement and implementation schedule	13

List of Annexure

Annexure 1: Process Flow Diagram	14
Annexure 2: Detailed technology assessment report – EE Motor	15
Annexure 3: Detailed drawing for civil work required for EE Motor	16
Annexure 4: Detailed financial calculations & analysis	17
Annexure 5: Details of procurement and implementation plan.....	21
Annexure 6: Details of technology/equipment and service providers	22
Annexure 7: Quotation or techno-commercial bid.....	23

List of Table

Table 1.1: Energy consumption of typical units.....	3
Table 1.2: Specific energy consumption for typical units	3
Table 1.3 Existing motor specifications.....	4
Table 1.4 Electricity consumption.....	5
Table 2.1: Energy Efficient motor Specifications.....	8
Table 4.1: Project detail cost	12
Table 4.2: Sensitivity analysis	13

List of Figure

Figure 1.1: General Process Flowchart of a Typical Ice Plant.....2

Lists of Abbreviations

BEE	- Bureau of Energy Efficiency
DPR	- Detailed Project Report
DSCR	- Debt Service Coverage Ratio
GHG	- Green House Gases
HP	- Horse Power
IRR	- Internal Rate of Return
MSME	- Micro Small and Medium Enterprises
MoP	- Ministry of Power
NPV	- Net Present Value
ROI	- Return on Investment
MoMSME	- Ministry of Micro Small and Medium Enterprises
SIDBI	- Small Industrial Development Bank of India

EXECUTIVE SUMMARY

APITCO Ltd. is executing BEE-SME program in Bhimavaram Ice Plants Cluster, supported by Bureau of Energy Efficiency (BEE) with an overall objective of improving the energy efficiency in cluster units.

Bhimavaram is renowned for the sea food business and is a big hub for fish and prawns culture. The prawns and fish are exported to various countries throughout the world. There are about 80 ice making units in the cluster. The major Energy forms used in the cluster are grid electricity and HSD oil. Electricity is used for driving the prime movers of compressors, pumps, agitators, drives and for lighting. HSD is used as fuel in DG sets for electricity generation in the event of failure of power supply.

The cost of energy as a percentage of end product cost (ice) cost varies anywhere between 48 to 54%. Majority of the industries located in Bhimavaram are engaged in production of ice blocks required for storage and transportation purpose of the sea food. The major component of the ice production is energy cost next to the labour cost.

The refrigeration compressor motor is the major energy consuming equipment of the ice making units. The motor is used to drive the refrigeration compressor through V belt drive. The motors installed for driving the refrigeration compressor in the cluster units are of very old and are inefficient. As per the detailed studies undertaken in various units of the cluster and based on the discussions with the supervisors and workers, the motors installed for refrigeration compressor are re wound number of times due to burning of the windings. It is well known fact that the re wound motors will have less efficiency and hence increasing power consumption.

Installation of new energy efficient motor for compressor would lead to electricity saving upto 29147 kWh per year due to improve efficiency.

The DPR highlights the details of the study conducted for assessing the potential for reducing electricity consumption by installing new efficient motor for compressor in various units of the cluster, possible electricity savings and its monetary benefit, availability of the technologies/design, local service providers, technical features and proposed equipment specifications, various barriers in implementation, environmental aspects, estimated GHG reductions, capital cost, financial analysis, and schedule of project Implementation.

This bankable DPR also found eligible for subsidy scheme of MoMSME for “Technology and Quality Upgradation Support to Micro, Small and Medium Enterprises” under “National

Manufacturing and Competitiveness Programme”. The key indicators of the DPR including the Project cost, debt equity ratio, monetary benefit and other necessary parameters are given in table below:

Sr. No.	Particular	Unit	Value
1	Project cost	(in Lakh)	1.88
2	Electricity Savings	kWh/annum	29147
3	Monetary benefit	(in Lakh)	1.09
4	Simple payback period	Years	1.72
5	NPV	(in Lakh)	2.32
6	IRR	%age	42.53
7	ROI	%age	27.12
8	Average DSCR	Ratio	2.43
9	CO ₂ emission reduction	MT/year	23
10	Process down time	Days	2

The projected profitability and cash flow statements indicate that the project implementation i.e. installation of energy efficient motor will be financially viable and technically feasible solution for the cluster.

ABOUT BEE'S SME PROGRAM

Bureau of Energy Efficiency (BEE) is implementing a BEE-SME Programme to improve the energy performance in 29 selected SMEs clusters. Bhimavaram Ice Making Units Cluster is one of them. The BEE's SME Programme intends to enhance the energy efficiency awareness by funding/subsidizing need based studies in SME clusters and giving energy conservation recommendations. For addressing the specific problems of these SMEs and enhancing energy efficiency in the clusters, BEE will be focusing on energy efficiency, energy conservation and technology up-gradation through studies and pilot projects in these SMEs clusters.

Major activities in the BEE -SME program are furnished below:

Activity 1: Energy use and technology audit

The energy use technology studies would provide information on technology status, best operating practices, gaps in skills and knowledge on energy conservation opportunities, energy saving potential and new energy efficient technologies, etc for each of the sub sector in SMEs.

Activity 2: Capacity building of stake holders in cluster on energy efficiency

In most of the cases SME entrepreneurs are dependent on the locally available technologies, service providers for various reasons. To address this issue BEE has also undertaken capacity building of local service providers and entrepreneurs/ Managers of SMEs on energy efficiency improvement in their units as well as clusters. The local service providers will be trained in order to be able to provide the local services in setting up of energy efficiency projects in the clusters

Activity 3: Implementation of energy efficiency measures

To implement the technology up-gradation project in the clusters, BEE has proposed to prepare the technology based detailed project reports (DPRs) for a minimum of five technologies in three capacities for each technology.

Activity 4: Facilitation of innovative financing mechanisms for implementation of energy efficiency projects

The objective of this activity is to facilitate the uptake of energy efficiency measures through innovative financing mechanisms without creating market distortion.

1 INTRODUCTION

1.1 Brief Introduction about cluster

Bhimavaram is a town in the West Godavari District in the state of Andhra Pradesh, India. It is located 395 kilometers east of state capital Hyderabad. Bhimavaram is renowned for the sea food business and is a big hub for fish and prawns culture. The prawns and fish are exported to various countries throughout the world. There are about 80 ice making units in the cluster. The major Energy forms used in the cluster are grid electricity and HSD oil. Electricity is used for driving the prime movers of compressors, pumps, agitators, drives and for lighting. HSD is used as fuel in DG sets for electricity generation in the event of failure of power supply.

The cost of energy as a percentage of end product cost (ice) cost varies anywhere between 48 to 54%. Majority of the industries located in Bhimavaram are engaged in for the next batch. The removed ice blocks are further crushed into smaller pieces production of ice blocks required for storage and transportation purpose of the sea food.

1.1.1 Production process

Raw water is pumped from local available water bodies such as pond / stream through raw water pump to overhead tank .

The production area of the plant has an Ice tank made of concrete. The ice tank contains the direct expansion coils, equally distributed throughout the tank and these coils are submerged in brine. The tank is provided with a suitable frame of hard wood for support the ice cans and a propeller or agitator for keeping the brine in motion: the brine in the tank acts as a medium of contact only, the ammonia evaporating in the ice coils extracts the heat from the brine, which again absorbs the heat for the water in the cans.

Raw water from overhead tank is filled into the ice cans. Water is chilled for 48 hours for complete ice block formation. The sp. gravity of brine is maintained at 1180 by adding salt of required quantity. Ice cans of fully formed ice blocks are removed from the chilling tank. The cans are emptied of the ice blocks and replaced into the chilling tank with water by ice crushers and loaded into plastic crates for transportation.

Detailed of process flow chart are finished in Figure 1.1 below:

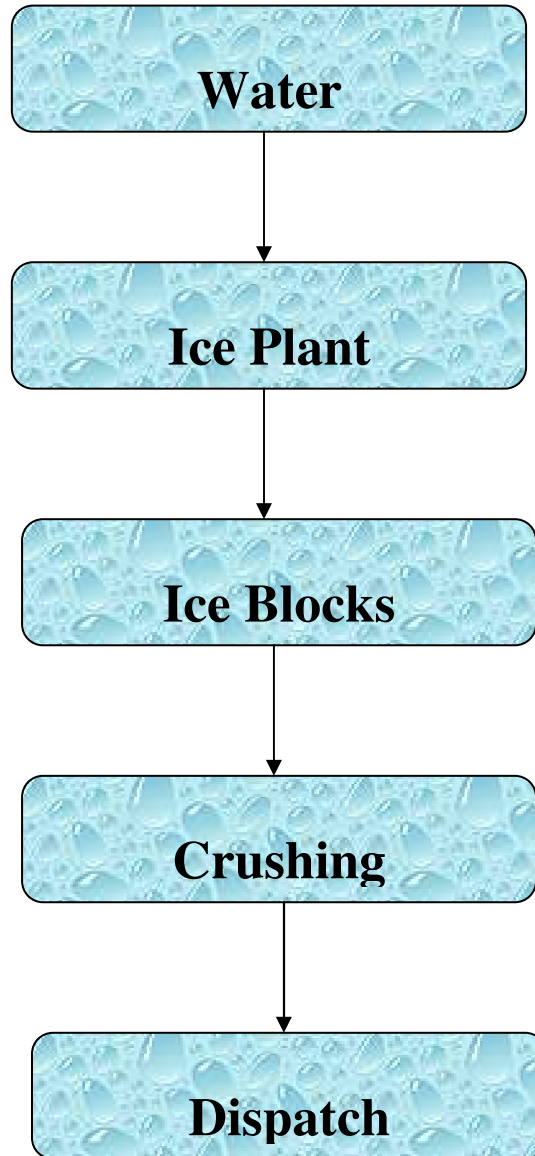

Figure 1.1: General process flowchart of a typical ice making unit

1.2 Energy performance in existing situation

1.2.1 Fuel and electricity consumption of a typical unit in the cluster

The main energy form used in a typical ice making unit in the cluster is electricity and HSD. Electricity is used for driving the prime movers of Compressors, pumps, agitators, ice crushers, lighting etc. The HSD is used as fuel in generators for electricity generation during power failures of grid electricity and is used in emergency situations only. The energy consumption of three typical ice making units in the cluster using low efficient compressor motor is furnished in Table 1.1 below:

Table 1.1: Energy consumption of typical units

S.No	Unit Name	Grid Electricity Consumption (MWh/annum)	HSD Consumption (Liters/annum)	Ice Production (tons/annum)
1	M/s Sai Ratna Ice Factory	438.9	5133	4200
2	M/s. Devi Ice Factory	456.0	6400	4000
3	M/s. Krishna Teja Ice Factory	622.73	7283	5700

1.2.2 Average production by a typical unit in the cluster

The average production in a typical ice making unit is between 4200 to 5700 tons of ice per annum.

1.2.3 Specific Energy Consumption

The major source of energy for ice making is electricity taken from grid and DG set and the specific electricity consumption per ton of ice production for typical units is furnished in Table 1.2 below:

Table 1.2: Specific energy consumption for typical units

Sr. No.	Unit Name	Units	Specific energy Consumption
1	M/s Sai Ratna Ice Factory	kWh/tons	110
2	M/s. Devi Ice Factory	kWh/tons	120
3	M/s. Krishna Teja Ice Factory	kWh/tons	115

The Specific Energy Consumption is high due to lower plant utilization with respect to Installed Capacity of the plant.

1.3 Existing technology/equipment

1.3.1 Description of existing technology

The motors installed for driving the refrigeration compressor in the cluster units are of very old and inefficient. As per the detailed studies undertaken in various units of the cluster and based on the discussions with the supervisors and workers, the motors installed for refrigeration compressor are rewinded number of times due to burning of the windings and it is a common practice for SME owners in the cluster.. It is well known fact that the re-winded motors will have less efficiency and hence increasing power consumption.

Power costs will certainly continue to rise and further escalate motor operating expense. So the question of how repair affects motor efficiency is an important one. Some claim a rewind motor is never as efficient as the original; others say a well-executed rewind can be better than the original design. These differences in perception suggest there may be several factors involved. Armed with the right information, understanding the factors that affect rewind performance does not need to be complicated. The ability of the repair shop to analyze and replace those parts which most influence losses, such as the stator core, the windings, and the rotor, will affect the outcome of a rewind.

A detail of existing compressor motor is given in the Table 1.3 below:

Table 1.3 Existing motor specifications

S.No	Details	Compressor motor
1	Rated HP	75
2	Rated Voltage	415
3	Rated Amps	130
4	Frequency	50 Hz
5	Power Consumption (kW)	52.72
6	Transmission system	V belt drive
7	RPM	1485

1.3.2 Its role in the whole process

The refrigeration compressor motor is the major energy consuming equipment of the ice making units. The motor is used drive the refrigeration compressor through V belt drive.

1.4 Establishing the baseline for the equipment

1.4.1 Design and operating parameters

The present power consumption of a motor is 52.72 kW. The motor is operated continuously for 24 hours in a day and for 350 days in a year.

1.4.2 Electricity consumption in existing system

The electricity consumption of refrigeration compressor motors of three cluster units is given in Table 1.4 below:

Table 1.4 Electricity consumption

S. No	Name of the unit	Installed Motor Capacity (HP)	Actual Power consumption (kW)
1	M/s. Devi Ice Factory	75	52.72
2	M/s Sai Ratna Ice Factory	75	54.40
3	M/s. Krishna Teja Ice Factory	75	53.31

1.4.2 Operating efficiency of the existing motor

The detailed energy audit studies had been undertaken in various units of the cluster to evaluate the motor efficiencies. Based on the age and number of the times motor is re-winded, the efficiency of the motor is found about 88%, against 94.2% efficiency of energy efficient motor available in the market.

1.5 Barriers for adoption of new and energy efficient technology / equipment

1.5.1 Technological Barriers

The major technical barriers that prevented the implementation of the energy efficient motors in the cluster are:

- Dependence on local equipment suppliers and availability of the motors at lower cost.
- Lack of awareness of the energy efficient motors.

1.5.2 Financial Barrier

The replacement of bigger size motors requires high investment and the repair and rewinding of the motor will cost very less. Hence, many of the owners don't show interest due to high initial investment and lack of financial strength to invest. Further, the lack of awareness of the losses and monetary benefit of energy efficient motors also one of the major factor for implementing the energy efficient motors.

Energy Efficiency Financing Schemes such as SIDBI's, if focused on the cluster, will play a catalytic role in implementation of identified energy conservation projects & technologies. The cluster has significant potential for implementing energy efficiency motors.

1.5.3 Skilled manpower

Not applicable

1.5.4 Other barrier(s)

Information on the energy efficient technologies not available among cluster unit owners, though the suppliers are available locally of energy efficient motors, the information was not disseminated among cluster units.

2. TECHNOLOGY/EQUIPMENT FOR ENERGY EFFICIENCY IMPROVEMENTS

2.1 Detailed description of technology/equipment selected

2.1.1 Description of equipment

The project activity is replacement of inefficient motors with new energy efficient motors. The new motor will have overall efficiency of more than 94.2% at full and part load conditions. These motors are available in TEFC construction for use in safe areas and also in flameproof enclosure for use in Hazardous areas.

The high energy efficiency motors having the following special features:

- Low loss special grade of thinner laminations. This reduces the Iron loss even at partial loads.
- Thicker conductors and more copper contents reduce copper loss due to lower resistance.
- Longer core length, reduced and uniform air gap between stator and rotor to reduce stray losses.
- Special design of fan and fan cover to reduce windage losses

Considering the above facts and for reducing electricity consumption of the motors, it is suggested to install energy efficient motors.

Advantage

Best performance even at partial loads:

The benefits of using these motors in continuous duty applications like Blowers, Compressors, Fans, Exhausters, and Pumps etc result the energy savings at full and part load conditions.

In many applications the load factor of the motor will be range of 60% to 80%. The efficiency curve of standard motor is dropping in nature i.e., there is a sharp fall in efficiency at partial loads. But the energy efficient motors have a flat efficiency curve and hence the fall in efficiency is marginal. Thus energy saving is significant even in part loads.

2.1.2 Technology /Equipment specifications

The detailed specification of the motor suggested is furnished in table 2.1 below:

Table 2.1: Energy Efficient motor Specifications

S. No.	Parameter	Unit	Value
1	Rated Capacity	HP	75
2	Rated Current	Amps	92
3	Speed	RPM	1480
4	Efficiency	% age	94.2
5	Power Factor	% age	0.88

2.1.3 Justification of the technology selected & Suitability

The refrigeration compressor motors are major energy consuming equipment in Ice Making Cluster at Bhimavaram. Based on the detailed energy audits conducted for various motors installed in cluster units, the motors are age old and rewinded number of time which leads to reduction in efficiency and high power consumption. But the new energy efficient motors will have overall efficiency of 94.2% (at full load).

The following benefits are possible for selection of this technology

- Energy efficient motors will reduce electricity consumption
- It reduces the GHG emissions
- Lower payback period for Continuous Operation
- High power factor
- Flat efficiency curve
- Higher Motor life

2.1.4 Superiority over existing technology/equipment

The following are the superior features of energy efficient motors over existing motors

- The efficiency curve is almost flat between 60 to 100 % load, resulting in higher energy savings as in most of the cases the motor is not always fully loaded
- The special design features also result in lower operating temperatures which enhance the life of motor and reduce the maintenance costs.
- These motors have inherently low noise and vibration and help in conservation of environment.

- These motors are with highest power factor in the industry due the special exclusive design.
- The higher power factor reduces the currents in the cables supplying power to motor and this reduces cable loss,
- Improving the system efficiency, sometimes this allows even a lower cable size saving tremendously on capital costs.
- Saving is also made by reducing capacitors required to improve power factor

2.1.5 Availability of the proposed technology/equipment

The energy efficient motor suppliers are available at Hyderabad and Vijayawada. The details of the suppliers are provided in Annexure-6.

2.1.6 Source of technology/equipment for the project

The source of the technology is indigenous and is locally available.

2.1.7 Service/technology providers

A detail of energy efficient motors suppliers has been furnished in Annexure 6.

2.1.8 Terms of sales

No any specific terms and conditions for sale of Energy efficient motor.

2.1.9 Process down time during implementation

The process down time for installation of energy efficient motor is considered two days for dismantling the existing motor and installation of new motor and providing electrical connections to the motor.

2.2 Life cycle assessment and risks analysis

The life of the energy efficient motor is considered at 20 years. There is no risk involved as the motor are technology proven and are successfully in operation in other industries of the country.

2.3 Suitable unit/plant size in terms of capacity/production

The motors are selected similar to the existing capacity of the motor and actual power drawn at full load based on energy audits carried out plus 20% margin to overcome sudden load and also as recommended by the refrigeration plant supplier.

3. ECONOMIC BENEFITS OF NEW ENERGY EFFICIENT TECHNOLOGY

3.1 Technical benefits

3.1.1 Fuel savings per year

No fuel saving is possible due to implementation of proposed system.

3.1.2 Electricity savings per year

The efficiency of the new energy efficiency motor is more than the existing motor which will lead to reduction in electricity consumption. The power savings due to installation of new energy efficient motor would be 29147 kWh per annum. Details of electricity saving calculation are given at Annexure 2.

3.1.3 Improvement in product quality

There is no significant impact on the product quality.

3.1.4 Increase in production

There is no significant effect on production capacity.

3.1.5 Reduction in raw material consumption

Raw material is consumption will be same.

3.1.6 Reduction in other losses

Due to improved power factor of new energy efficient motor, the distribution losses may also reduce.

3.2 Monetary benefits

The monetary benefit due to installation of new energy efficient motor is ` 1.09 lakh per annum due to reduction in electricity consumption. Details of monetary saving calculation are furnished in Annexure 2.

3.3 Social benefits

3.3.1 Improvement in working environment in the plant

As installation of new efficient motor may minimize the breakdowns and hence working environment may improve.

3.3.2 Improvement in skill set of workers

The technology selected for the implementation is new and energy efficient motor will create the awareness among the workforce on energy efficiency.

3.4 Environmental benefits

3.4.1 Reduction in effluent generation

None

3.4.2 Reduction in GHG emission such as CO₂, NO_x, etc

The major GHG emission reduction source is CO₂. The technology will reduce grid electricity consumption and emission reductions are estimated at 23 tons of CO₂ per annum due to implementation of the project activity.

3.4.3 Reduction in other emissions like SO_x

No significant impact on SO_x emissions.

4. INSTALLATION OF NEW ENERGY EFFICIENT MOTOR

4.1 Cost of technology/equipment implementation

4.1.1 Cost of technology/equipments

The total cost for motor is ` 1.73 lakh, which includes motor cost and other charges and discounts as per the Quotation in Annexure 7.

4.1.2 Other costs

Other charges include cabling and panel modification. Project cost details are furnished in Table 4.1 below:

Table 4.1: Project detail cost

Sr. No.	Particular	Unit	Value
1	New Energy Efficient motor	` in lakh	1.73
2	Panel, Switch & Cabling, Elec. and Modifications etc.	` in lakh	0.15
3	Total Investment	` in lakh	1.88

4.2 Arrangement of funds

4.2.1 Entrepreneur's contribution

The entrepreneur's contribution is 25% of total project cost, which works out at ` 0.47 lakh.

4.2.2 Loan amount

The term loan is 75% of the total project cost, which is ` 1.41 lakh.

4.2.3 Terms & conditions of loan

The interest rate is considered at 10.0% which is prevailing interest rate of SIDBI for energy efficiency related projects. The loan tenure is 5 years and the moratorium period is 6 months.

4.3 Financial indicators

4.3.1 Cash flow analysis

Considering the above discussed assumptions, the net cash accruals starting with ` 0.83 lakh in the first year operation and increases to ` 4.17 at the end of eighth year.

4.3.2 Simple payback period

The total project cost of the proposed technology is ₹ 1.68 lakh and monetary savings due to reduction in electricity consumption is ₹ 1.09 lakh and the simple payback period works out to be 1.72 years.

4.3.3 Net Present Value (NPV)

The Net present value of the investment at 10.0% interest rate works out to be ₹ 2.32 lakh.

4.3.4 Internal rate of return (IRR)

The after tax Internal Rate of Return of the project works out to be 42.53%. Thus the project is financially viable.

4.3.5 Return on investment (ROI)

The average return on investment of the project activity works out at 27.12%. The average DSCR is 2.43.

4.4 Sensitivity analysis in realistic, pessimistic and optimistic scenarios

A sensitivity analysis has been worked out to ascertain how the project financials would behave in different situations like there is an increase in power savings or decrease. For the purpose of sensitive analysis, two scenarios are considered are.

- Increase in power savings by 5%
- Decrease in power savings by 5%

In each scenario, other inputs are assumed as constant. The financial indicators in each of the above situation are indicated along with standard indicators.

Table 4.2: Sensitivity analysis

<i>Particulars</i>	<i>IRR</i> %	<i>NPV</i> ₹ in lakh	<i>ROI</i> %	<i>DSCR</i>
Normal	42.53%	2.32	27.12%	2.43
5% increase in power savings	45.25%	2.53	27.28%	2.55
5% decrease in power savings	39.79%	2.11	26.94%	2.31

4.5 Procurement and implementation schedule

The project is expected to be completed in 4 weeks from the date of release of purchase order. The detailed schedule of project implementation is furnished in Annexure 5.

ANNEXURE

Annexure 1: Process Flow Diagram

Process flow diagram will remain the same after implementation of proposed energy efficient motor.

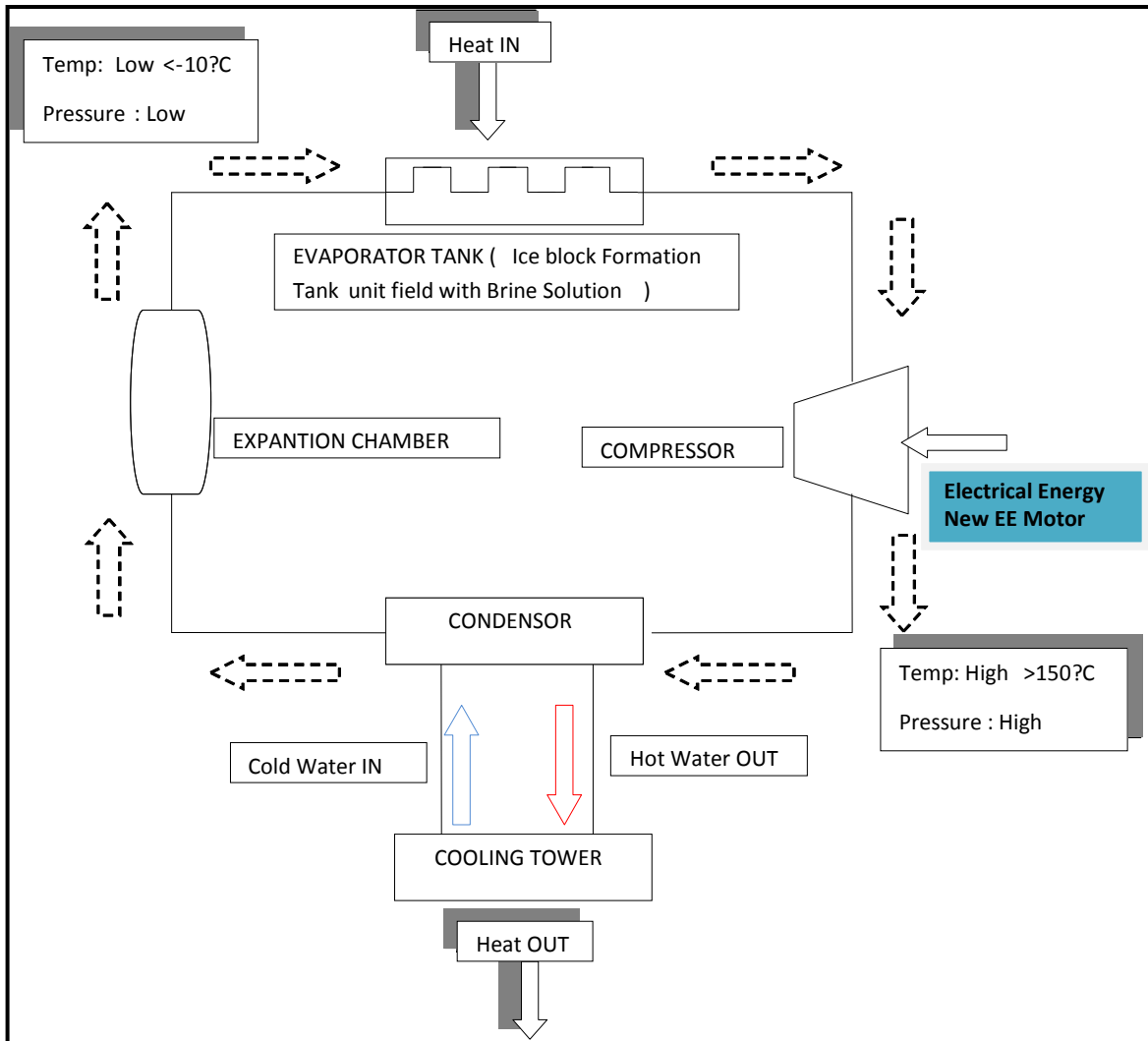

Annexure 2: Detailed technology assessment report – EE Motor

S.No	Particulars	Unit	Value
1	Present rated HP	HP	75
2	Power consumption in base case scenario (M/s. Devi Ice Factory)	kW	52.72
3	Efficiency of existing motor	% age	88
4	Efficiency of energy efficient motor	% age	94.2
5	Proposed power consumption	kWh	49.25
6	Power savings	kW	3.47
7	Total operating hours	hrs	24
8	Total operating days	days	350
9	Power savings per annum	kWh	29147
10	Monetary savings per annum (@ ₹3.75 per kWh)	₹ in lakh	1.09
11	Investment required for new energy efficient motor	₹ in lakh	1.88
12	Payback period	Years	1.72

Annexure 3: Detailed drawing for civil work required for EE Motor

HX+ 160...280 (Foot Mounted)

Mounting Designation B3, B6, B7, B8, V5, V6

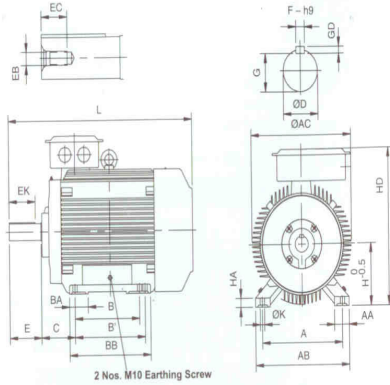

2 Nos. M10 Earthing Screw

Type	A	AA	AB	AC	B	B'	BA	BB	C	D-Tol.	E	EB	EC
HX+160ML	254	60	310	305	210	254	65	310	108	42-k6	110	M16	36
HX+180ML	279	58	324	348	241	279	58	324	121	48-k6			
HX+200ML	318	70	378	381	267	305	81	354	133	55-m6			
HX+225SM	356	65	416	442	286	311	83	380	149	60-m6	140	M20	42
HX+250M	406	80	473	495	349	-	93	406	168	65-m6			
HX+280SM	457	85	530	556	368	419	105	486	190	75-m6			

Type	EK	F	G	GD	H	HA	HD	K	L	Bearing	
										DS	NDS
HX+160ML	90	12	37	8	160	22	407	15	671	6309ZZ C3	6308ZZ C3
HX+180ML		14	42.5	9	180	26	446	15	706	6310ZZ C3	6309ZZ C3
HX+200ML		16	49	10	200	30	484	19	731	6312ZZ C3	6311ZZ C3
HX+225SM	115	16	49	10	225	32	562	19	833	6313 C3	6312 C3
HX+250M		18	53	11	250	40	612	24	910	6315 C3	6313 C3
HX+280SM		20	67.5	12	280	48	728	24	1040	6316 C3	6315 C3

* For HX+ 200MLC2, L= 770mm
 * For 160-250 frame: sheet metal terminal box, 280 frame: cast iron terminal box

HXF+ 160...280 (Flange Mounted)

Mounting Designation B5, V1

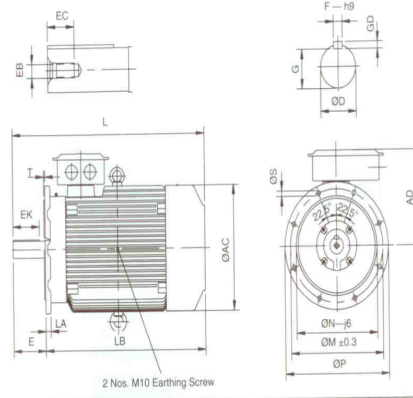

2 Nos. M10 Earthing Screw

Type	AC	AD	D-Tol.	E	EB	EC	EK	F	G	GD	L
HXF+160ML	305	247	42-k6	110	M16	36	90	12	37	8	671
HXF+180ML	348	266	48-k6					14	42.5	9	706
HXF+200ML	381	284	55-m6					16	49	10	731
HXF+225SM	442	337	60-m6	140	M20	42	115	16	49	10	833
HXF+250M	495	362	65-m6					18	53	11	910
HXF+280SM	556	448	75-m6					20	67.5	12	1040

Type	LA	LB	M	N-Tol.	P	S	T	Bearing	
								DS	NDS
HXF+160ML	16	561	300	250-j6	350	19	5	6309ZZ C3	6308ZZ C3
HXF+180ML	20	596	300	250-j6	350			6310ZZ C3	6309ZZ C3
HXF+200ML		621	350	300-j6	400			6312ZZ C3	6311ZZ C3
HXF+225SM	22	723	400	350-j6	450	19	5	6313 C3	6312 C3
HXF+250M		770	500	450-j6	550			6315 C3	6313 C3
HXF+280SM		900	500	450-j6	550			6316 C3	6315 C3

* For 160-200 frame flange mounted motors, 4 nos mounting holes are provided
 * For 225-280 frame flange mounted motors, 8 nos mounting holes are provided

Annexure 4: Detailed financial calculations & analysis

Assumptions

Name of the Technology		Energy Efficient Electric Motor		
Rated Capacity		75 HP		
Details	Unit	Value	Basis	
Installed Capacity	HP	75		
No of working days	Days	350		
No of operating hours	Hrs	24		
Proposed Investment				
Plant & Machinery	` (in lakh)	1.73		
Panel, Switch & Cabling etc.	` (in lakh)	0.15		
Total Investment	` (in lakh)	1.88		
Financing pattern				
Own Funds (Equity)	` (in lakh)	0.47	Feasibility Study	
Loan Funds (Term Loan)	` (in lakh)	1.41	Feasibility Study	
Loan Tenure	Years	5.00	Assumed	
Moratorium Period	Months	6.00	Assumed	
Repayment Period	Months	66.00	Assumed	
Interest Rate	%age	10.00%	SIDBI Lending rate	
Estimation of Costs				
O & M Costs	% on Plant & Equip	2.00	Feasibility Study	
Annual Escalation	%age	5.00	Feasibility Study	
Estimation of Revenue				
Electricity Saving	kWh/Year	29147		
Cost of electricity	`/kWh	3.75		
St. line Depn.	%age	5.28	Indian Companies Act	
IT Depreciation	%age	80.00	Income Tax Rules	
Income Tax	%age	33.99	Income Tax	

Estimation of Interest on Term Loan

` (in lakh)

Years	Opening Balance	Repayment	Closing Balance	Interest
1	1.41	0.06	1.35	0.16
2	1.35	0.16	1.19	0.13
3	1.19	0.24	0.95	0.11
4	0.95	0.28	0.67	0.08
5	0.67	0.40	0.27	0.05
6	0.27	0.27	0.00	0.01
		1.41		

WDV Depreciation

` (in lakh)

Particulars / years	1	2
Plant and Machinery		
Cost	1.88	0.38
Depreciation	1.51	0.30
WDV	0.38	0.08

Projected Profitability

` (in lakh)

Particulars / Years	1	2	3	4	5	6	7	8
Fuel savings	1.09	1.09	1.09	1.09	1.09	1.09	1.09	1.09
Total Revenue (A)	1.09	1.09	1.09	1.09	1.09	1.09	1.09	1.09
Expenses								
O & M Expenses	0.04	0.04	0.04	0.04	0.05	0.05	0.05	0.05
Total Expenses (B)	0.04	0.04	0.04	0.04	0.05	0.05	0.05	0.05
PBDIT (A)-(B)	1.06	1.05	1.05	1.05	1.05	1.04	1.04	1.04
Interest	0.16	0.13	0.11	0.08	0.05	0.01	0.00	0.00
PBDT	0.89	0.92	0.94	0.97	1.00	1.04	1.04	1.04
Depreciation	0.10	0.10	0.10	0.10	0.10	0.10	0.10	0.10
PBT	0.79	0.82	0.84	0.87	0.90	0.94	0.94	0.94
Income tax	0.00	0.21	0.32	0.33	0.34	0.35	0.35	0.35
Profit after tax (PAT)	0.79	0.61	0.52	0.54	0.56	0.58	0.59	0.59

Computation of Tax

` (in lakh)

Particulars / Years	1	2	3	4	5	6	7	8
Profit before tax	0.79	0.82	0.84	0.87	0.90	0.94	0.94	0.94
Add: Book depreciation	0.10	0.10	0.10	0.10	0.10	0.10	0.10	0.10
Less: WDV depreciation	1.51	0.30	-	-	-	-	-	-
Taxable profit	(0.62)	0.62	0.94	0.97	1.00	1.04	1.04	1.04
Income Tax	-	0.21	0.32	0.33	0.34	0.35	0.35	0.35

Projected Balance Sheet

` (in lakh)

Particulars / Years	1	2	3	4	5	6	7	8
Liabilities								
Share Capital (D)	0.47	0.47	0.47	0.47	0.47	0.47	0.47	0.47
Reserves & Surplus (E)	0.79	1.40	1.93	2.47	3.02	3.61	4.20	4.78
Term Loans (F)	1.35	1.19	0.95	0.67	0.27	0.00	0.00	0.00
Total Liabilities (D)+(E)+(F)	2.62	3.07	3.35	3.61	3.77	4.08	4.67	5.26
Assets	1	2	3	4	5	6	7	8
Gross Fixed Assets	1.88	1.88	1.88	1.88	1.88	1.88	1.88	1.88
Less Accm. Depreciation	0.10	0.20	0.30	0.40	0.50	0.60	0.70	0.80
Net Fixed Assets	1.78	1.68	1.58	1.49	1.39	1.29	1.19	1.09
Cash & Bank Balance	0.83	1.38	1.77	2.12	2.38	2.79	3.48	4.17
TOTAL ASSETS	2.62	3.07	3.35	3.61	3.77	4.08	4.67	5.26
Net Worth	1.26	1.88	2.40	2.94	3.49	4.08	4.67	5.25
Debt Equity Ratio	2.87	2.53	2.02	1.43	0.58	0.01	0.01	0.01

Projected Cash Flow

` (in lakh)

Particulars / Years	0	1	2	3	4	5	6	7	8
Sources									
Share Capital	0.47	-	-	-	-	-	-	-	-
Term Loan	1.41								
Profit After tax		0.79	0.61	0.52	0.54	0.56	0.58	0.59	0.59
Depreciation		0.10	0.10	0.10	0.10	0.10	0.10	0.10	0.10
Total Sources	1.88	0.89	0.71	0.62	0.64	0.66	0.68	0.69	0.69

Application									
Capital Expenditure	1.88								
Repayment Of Loan	-	0.06	0.16	0.24	0.28	0.40	0.27	0.00	0.00
Total Application	1.88	0.06	0.16	0.24	0.28	0.40	0.27	0.00	0.00
Net Surplus	-	0.83	0.55	0.38	0.36	0.26	0.41	0.69	0.69
Add: Opening Balance	-	-	0.83	1.38	1.77	2.12	2.38	2.79	3.48
Closing Balance	-	0.83	1.38	1.77	2.12	2.38	2.79	3.48	4.17

IRR

(in lakh)

Particulars / months	0	1	2	3	4	5	6	7	8
Profit after Tax		0.79	0.61	0.52	0.54	0.56	0.58	0.59	0.59
Depreciation		0.10	0.10	0.10	0.10	0.10	0.10	0.10	0.10
Interest on Term Loan		0.16	0.13	0.11	0.08	0.05	0.01	-	-
Cash outflow	(1.88)	-	-	-	-	-	-	-	-
Net Cash flow	(1.88)	1.06	0.84	0.73	0.72	0.71	0.69	0.69	0.69
IRR	42.53%								
NPV	2.32								

Break Even Point

(in lakh)

Particulars / Years	1	2	3	4	5	6	7	8
Variable Expenses								
Oper. & Maintenance Exp (75%)	0.03	0.03	0.03	0.03	0.03	0.04	0.04	0.04
Sub Total(G)	0.03	0.03	0.03	0.03	0.03	0.04	0.04	0.04
Fixed Expenses								
Oper. & Maintenance Exp (25%)	0.01	0.01	0.01	0.01	0.01	0.01	0.01	0.01
Interest on Term Loan	0.16	0.13	0.11	0.08	0.05	0.01	0.00	0.00
Depreciation (H)	0.10	0.10	0.10	0.10	0.10	0.10	0.10	0.10
Sub Total (I)	0.27	0.24	0.22	0.19	0.16	0.12	0.11	0.11
Sales (J)	1.09	1.09	1.09	1.09	1.09	1.09	1.09	1.09
Contribution (K)	1.06	1.06	1.06	1.06	1.06	1.06	1.06	1.05
Break Even Point (L= G/I)	25.62%	22.44%	20.54%	18.34%	15.36%	11.36%	10.62%	10.70%
Cash Break Even {(I)-(H)}	16.29%	13.09%	11.18%	8.96%	5.97%	1.95%	1.20%	1.26%
Break Even Sales (J)*(L)	0.28	0.25	0.22	0.20	0.17	0.12	0.12	0.12

Return on Investment

(in lakh)

Particulars / Years	1	2	3	4	5	6	7	8	Total
Net Profit Before Taxes	0.79	0.82	0.84	0.87	0.90	0.94	0.94	0.94	7.04
Net Worth	1.26	1.88	2.40	2.94	3.49	4.08	4.67	5.25	25.97
									27.12%

Debt Service Coverage Ratio

(in lakh)

Particulars / Years	1	2	3	4	5	6	7	8	Total
Cash Inflow									
Profit after Tax	0.79	0.61	0.52	0.54	0.56	0.58	0.59	0.59	3.61
Depreciation	0.10	0.10	0.10	0.10	0.10	0.10	0.10	0.10	0.60
Interest on Term Loan	0.16	0.13	0.11	0.08	0.05	0.01	0.00	0.00	0.55
Total (M)	1.06	0.84	0.73	0.72	0.71	0.69	0.69	0.69	4.75

DEBT

Interest on Term Loan	0.16	0.13	0.11	0.08	0.05	0.01	0.00	0.00	0.55
Repayment of Term Loan	0.06	0.16	0.24	0.28	0.40	0.27	0.00	0.00	1.41
Total (N)	0.22	0.29	0.35	0.36	0.45	0.28	0.00	0.00	1.96
Average DSCR (M/N)	2.43								

Annexure 5: Details of procurement and implementation plan

Project Implementation schedule

S. No	Activity	Weeks			
		1	2	3	4
1	Placement of Orders for Equipment				
2	Supply of motor				
3	Installation of the motor				
4	Trial runs				

Process down time

S. No	Activity	Weeks			
		1	2	3	4
1	Dismantling of the existing motor				
2	Electricity connections and modification of the pipe lines				
3	Installation of the motor				
4	Trial runs				

The process down time is considered for only two days.

Annexure 6: Details of technology/equipment and service providers

<i>Equipment details</i>	<i>Source of technology</i>	<i>Service/technology providers</i>
Energy Efficient Motors	SIEMENS	SLR Enterprises D.No:3464, (4-3-1 to 6) 3 rd Floor, "Dundoo Vihar" R.P.Road Secunderabad-500 003 Ph No:040-66588120 Fax:040-66338262 Mobile:9849006201

Annexure 7: Quotation or techno-commercial bid

QUOTATION



SLR ENTERPRISES

Ph : (O) 66568120
 Telefax : 66338262
 Mobile : 9849006201

AUTHORISED DEALER FOR :

FINOLEX CABLES LTD, ROTOMOTIVE - MOTORS & WORM GEAR BOXES

D. No. 3464, (4-3-1 to 6) 3rd Floor, "Dundoo Vihar", R.P. Road, Secunderabad - 500 003.

Qtn. No. : 359

Date : 24/12/10

Ref. No. :

S.No.	DESCRIPTION	Qty.	Unit Price	Amount	
				Rs.	Ps.
1	SIEMENS MAKE 1500 RPM FOOT MOUNTING MOTOR EFFI 60 HP ISED 223-4Y2SD		198,400/-		
2	75HP ISED 254-4Y2SD		252,500/-		
3	100 HP ISED 281-4Y2SD		323,150/-		
4	120 HP ISED 284-4Y2SD		374,910/-		
5	150 HP ISED 311-4Y2SD		453,900/-		
LESS DISCOUNT : 4.5%					
EXERCISE DUTY : 10.3%					

TIN : 28630156311

APGST No. SEC/10/1/2734/96-97 CST No. : SEC/10/1/2352/2000-2001

Valid from : 1-4-1996 w.e.f. : 1-6-2000

Terms & Conditions :

- 1) Prices : *vat at 14.5% extra*
- 2) Delivery : *ex-Stock*
- 3) F.O.R. : *Sec. Road*
- 4) Payment : *25% advance balance against delivery.*
- 5) Validity : *One meet.*

for **SLR ENTERPRISES**

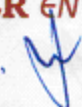



Bureau of Energy Efficiency (BEE)

(Ministry of Power, Government of India)

4th Floor, Sewa Bhawan, R. K. Puram, New Delhi – 110066

Ph.: +91 – 11 – 26179699 (5 Lines), Fax: +91 – 11 – 26178352

Websites: www.bee-india.nic.in, www.energymanagertraining.com



APITCO Limited

8th floor, Parisrama Bhavan

Basheerbagh, Hyderabad -500004

Phones: +91- 040-23237333, 23237981,

Fax: +91-40-23298945

E-mail: hyd1_apitco@bsnl.in

Website: www.apitco.org



India SME Technology Services Ltd

DFC Building, Plot No.37-38,

D-Block, Pankha Road,

Institutional Area, Janakpuri, New Delhi-110058

Tel: +91-11-28525534, Fax: +91-11-28525535

Website: www.techsmall.com