

**DETAILED PROJECT REPORT
ON
ENERGY EFFICIENT GAS FIRED HOT AIR GENERATOR – 30,000 kCal/hr
(AHMEDABAD CHEMICAL CLUSTER)**



Bureau of Energy Efficiency

Prepared By



Reviewed By



ENERGY EFFICIENT GAS FIRED HOT AIR GENERATOR

AHMEDABAD CHEMICAL CLUSTER

BEE, 2010

***Detailed Project Report on Energy Efficient Gas Fired Hot Air Generator
(30,000 kCal/hr)***

Chemical SME Cluster, Ahmedabad, Gujarat (India)

New Delhi: Bureau of Energy Efficiency;

Detail Project Report No. **AMD/CHM/HGG/04**

For more information

Bureau of Energy Efficiency (BEE)
(Ministry of Power, Government of India)
4th Floor, Sewa Bhawan
R. K. Puram, New Delhi – 110066

Telephone +91-11-26179699

Fax +91-11-26178352

Websites: www.bee-india.nic.in

Email: jsood@beenet.in/ pktiware@beenet.in

Acknowledgement

We are sincerely thankful to the Bureau of Energy Efficiency, Ministry of Power, for giving us the opportunity to implement the 'BEE SME project in "Ahmedabad Chemical Cluster". We express our sincere gratitude to all concerned officials for their support and guidance during the conduct of this exercise.

Dr. Ajay Mathur, Director General, BEE

Smt. Abha Shukla, Secretary, BEE

Shri Jitendra Sood, Energy Economist, BEE

Shri Pawan Kumar Tiwari, Advisor (SME), BEE

Shri Rajeev Yadav, Project Economist, BEE

Winrock International India(WII) is also thankful to "Green Environment Co-operative Society, Vatva" for their valuable inputs, co-operation, support and identification of the units for energy use and technology audit studies and facilitating the implementation of BEE SME program in Ahmedabad Chemical Cluster.

We take this opportunity to express our appreciation for the excellent support provided by Chemical Unit Owners, Local Service Providers, and Equipment Suppliers for their active involvement and their valuable inputs in making the program successful and in completion of the Detailed Project Report (DPR).

WII is also thankful to all the SME owners, plant in charges and all workers of the SME units for their support during the energy use and technology audit studies and in implementation of the project objectives.

Winrock International India

New Delhi

Contents

<i>List of Annexure</i>	<i>vii</i>
<i>List of Tables</i>	<i>vii</i>
<i>List of Figures</i>	<i>viii</i>
<i>List of Abbreviation</i>	<i>viii</i>
<i>Executive summary</i>	<i>ix</i>
<i>About BEE'S SME program</i>	<i>xi</i>
1 INTRODUCTION	1
1.1 Brief Introduction About Cluster.....	1
1.1.1 Existing Production Process	1
1.2 Energy Performance In Ahmedabad Chemical Cluster	2
1.2.1 Specific Energy Consumption	3
1.3 Identification Of Existing Technology/ Equipment.....	3
1.3.1 Description Of Equipment	3
1.3.2 Technical Gap In Conventional Wood Fired Hag	4
1.3.3 Specification Of Existing System.....	5
1.3.4 Role In The Process	6
1.3.5 Need For Up Gradation Of Existing Equipment.....	6
1.4 Baseline Energy Consumption Of Existing Equipment	7
1.4.1 Design And Operating Parameters	7
1.4.2 Specific Fuel Consumption In Existing System	7
1.4.3 Energy Audit Methodology	8
1.5 Barriers In Adoption Of Proposed Technology/Equipment.....	9
1.5.1 Technological Barrier	9
1.5.2 Financial Barrier.....	10
1.5.3 Skilled Manpower	10
2 IMPLEMENTATION OF PROPOSED TECHNOLOGY/EQUIPMENT	12
2.1 Description Of Proposed Equipment	12
2.1.1 Comparison Of Conventional Hag With Energy Efficient Gas Fired Hag	12
2.1.2 Equipment Specification.....	13
2.1.3 Suitability Over Existing System	13
2.1.4 Superiority Over Existing System.....	13
2.1.5 Technical Specifications	13
2.1.6 Availability Of Proposed Equipment.....	13

2.1.7	Equipment Providers.....	14
2.1.8	Terms And Conditions In Sales Of Energy Efficient Hag.....	14
2.2	Process Down Time During Implementation.....	14
2.3	Suitable Unit For Proposed Equipment	14
3	ECONOMIC BENEFITS OF ENERGY EFFICIENT HOT AIR GENERATOR.....	15
3.1	Energy & Monetary Benefits.....	15
3.1.1	Fuel Saving.....	15
3.1.2	Electrciity Saving	15
3.1.2	Monetary Benefit.....	15
3.2	Environmental Benefits	15
3.2.1	Reduction Of Deforestation.....	15
3.2.2	Ghg Emission Reductions.....	15
3.2.3	Cdmability Of The Project	16
3.3	Social Benefits	16
3.3.1	Impact On Working Environment	16
3.3.2	Impact On Manpower Skills	16
3.3.3	Impact On Wages/Emoluments	16
3.4	Other Benefits (If Any).....	16
3.4.1	Productivity Improvements.....	16
3.4.2	Quality Improvements	16
3.4.3	Easy Operation& Maintenance	17
4	ECONOMICS & IMPLEMENTATION OF ENERGY EFFICIENT HAG	18
4.1	Cost Of Project Implementation.....	18
4.1.1	Equipment Cost	18
4.1.2	Other Cost	18
4.2	Arrangement Of Funds.....	18
4.2.1	Entrepreneurs Contribution	18
4.2.2	Loan Amount	18
4.2.3	Terms & Conditions Of Loan.....	19
4.3	Financial Indicators	19
4.3.1	Cash Flow Analysis	19
4.3.2	Simple Payback Period.....	19
4.3.3	Net Preset Value (Npv)	19
4.3.4	Internal Rate Of Return (Irr)	19
4.3.5	Return On Investment (Roi)	20
4.4	Sensitivity Analysis.....	20

4.5	Procurement And Implementation Schedule	20
-----	---	----

List of Annexure

Annexure-1 Energy audit reports of conventional hot air generator.....	1
Annexure 2 Process flow diagram	1
Annexure-3 Detailed technical assessment report	2
Annexure-4 Electrical & civil works drawing of energy efficient HAG	4
Annexure-5 Detailed cash flow evaluations of energy efficient HAG	6
Annexure-6 Details of procurement and implementation plan	10
Annexure-7 Details of equipment and service providers	11
Annexure 8 Quotations of energy efficient gas fired hot air generator.....	12

List of Tables

Table 1.1 Annual Energy consumption and production.....	3
Table 1.2 Specific energy consumption of a typical unit	3
Table 1.3 Specification of existing hot air generator	5
Table 2.1 Comparison of conventional equipment and proposed equipment	12
Table 2.2 Technical specifications.....	13
Table 4.1 Details of proposed equipment installation cost	18
Table 4.1 Financial parameters of energy efficient hot air generator	20
Table 4.2 Sensitivity analysis	20

List of Figures

Figure 1.1: Process flow chart	2
Figure1.2 Hot air generator operations at a chemical industry	4
Figure1.3: Energy audit methodology	9

List of Abbreviations

MT	Metric Tonne
kWh	kilo Watt Hour
Gol	Government Of India
MoMSME	Ministry of Micro Small and Medium Enterprises
GHG	Green House Gas
BEE	Bureau of Energy Efficiency
DPR	Detailed Project Report
O&M	Operational & Maintenance
NPV	Net Present Values
ROI	Return on Investment
IRR	Internal Rate Of Return
DSCR	Debt Service Coverage Ratio
PBT	Profit Before Tax
PAT	Profit After Tax
ID	Induced Draft
FD	Forced Draft
HAG	Hot Air Generator
DBT	Dry Bulb Temperature
SIDBI	Small Industries Development Bank of India

EXECUTIVE SUMMARY

Winrock International India is executing BEE-SME program in Ahmadabad chemical Cluster, supported by Bureau of Energy Efficiency (BEE) with an overall objective of improving the energy efficiency in cluster units.

Ahmadabad chemical cluster is one of the largest chemical clusters in India; accordingly this cluster was chosen for energy efficiency improvements by implementing energy efficient measures / technologies, so as to facilitate maximum replication in other chemical clusters in India.

The main energy forms used in the cluster units are wood. Wood is used as fuel in hot air generator for drying process. The cost incurred in the drying process constitutes major portion in the overall energy cost in majority of chemical industries in Ahmedabad cluster.

Function of hot air generator in chemical units is to generate hot air to dry chemicals in different types of dryers. It is evident that drying is one of the major energy and time consuming process in the overall manufacturing process of chemical units. Apart from the energy and time, final product quality depends on quality of drying.

During energy audit, it was observed that most of the chemical units are using wood fired inefficient hot air generator for generation of hot air and it is found that the efficiencies of the existing hot air generator is abysmally low.

Implementation of new energy efficient Gas fired hot air generator of capacity 30,000 kCal/hr having efficiency higher than the conventional system, will completely replace the wood consumption in existing wood fired hot air generator which work out to be 1,30,000 kg per year. However, this intervention will increase the electricity consumption.

This DPR highlights the details of the study conducted for assessing the potential for replacement of conventional wood fired hot air generator by new energy efficient gas fired hot air generator , possible energy saving, and its monetary benefit, availability of the technologies/design, local service providers, technical features & proposed equipment specifications, various barriers in implementation, environmental aspects, estimated GHG reductions, capital cost, financial analysis, sensitivity analysis for three different scenarios and schedule of Project Implementation

This bankable DPR also found eligible for subsidy scheme of MoMSME for “Technology and Quality Upgradation Support to Micro, Small and Medium Enterprises” under “National Manufacturing and Competitiveness Programme”. The key indicators of the DPR including the Project cost, debt equity ratio, monetary benefit and other necessary parameters are given in table:

S. No	Particular	Unit	Value
1	Project cost	Rs. (in Lakh)	2.50
2	Wood Consumption (in existing scenario)	tonnes/year	130
3	LNG consumption (in proposed case)	Nm3/year	14940
4	Monetary benefit	Rs. (in Lakh)	0.76
5	Debit equity ratio	Ratio	3:1
6	Simple payback period	years	3.29
7	NPV	Rs. (in Lakh)	0.58
8	IRR	%	15.80
9	ROI	%	20.13
10	DSCR	Ratio	1.40
11	Process down time	Days	7
12	CO ₂ reduction	Tons/year	93

The projected profitability and cash flow statements indicate that the proposed project implementation i.e. energy efficient gas fired HAG with existing wood fired HAG will be financially viable and technically feasible.

ABOUT BEE'S SME PROGRAM

Bureau of Energy Efficiency (BEE) is implementing a BEE-SME Programme to improve the energy performance in 25 selected SMEs clusters. Ahmadabad chemical Cluster is one of them. The BEE's SME Programme intends to enhance the energy efficiency awareness by funding/subsidizing need based studies in SME clusters and giving energy conservation recommendations. For addressing the specific problems of these SMEs and enhancing energy efficiency in the clusters, BEE will be focusing on energy efficiency, energy conservation and technology up gradation through studies and pilot projects in these SMEs clusters.

Major activities in the BEE -SME program are furnished below:

Activity 1: Energy use and technology audit

The energy use technology studies would provide information on technology status, best operating practices, gaps in skills and knowledge on energy conservation opportunities, energy saving potential and new energy efficient technologies, etc for each of the sub sector in SMEs.

Activity 2: Capacity building of stake holders in cluster on energy efficiency

In most of the cases SME entrepreneurs are dependent on the locally available technologies, service providers for various reasons. To address this issue BEE has also undertaken capacity building of local service providers and entrepreneurs/ managers of SMEs on energy efficiency improvement in their units as well as clusters. The local service providers will be trained in order to be able to provide the local services in setting of energy efficiency projects in the clusters

Activity 3: Implementation of energy efficiency measures

To implement the technology up gradation projects in clusters, BEE has proposed to prepare the technology based detailed project reports (DPRs) for a minimum of five technologies in three capacities for each technology.

Activity 4: Facilitation of innovative financing mechanisms for implementation of energy efficiency projects

The objective of this activity is to facilitate the uptake of energy efficiency measures through innovative financing mechanisms without creating market distortion

1 INTRODUCTION

1.1 Brief introduction about Cluster

Ahmadabad city and its surrounding areas have various types of chemical SME units like dyes; dye Intermediates and pigments manufacturing units. All these chemical manufacturing units are located at Vatva, Naroda and Odhav industrial areas. There are about 500 chemical units in Vatva, 60 units in Naroda and 40 units in Odhav. Most of manufacturing units in these areas are in operation from last 10 to 15 years.

Ahmadabad chemical cluster like many other SME clusters, were in a dire state in regard to the energy efficiency and conservation. In almost all units, whether big or small, there had been no conscious efforts to take up energy conservation and energy efficiency measures as a part of day to day operations. In majority of cases, the small scale entrepreneur are not even aware of the measures that could bring down the energy cost, which will automatically have positive bearing on the overall manufacturing cost. Some of the bigger units had experimented with few parameters to improve the energy efficiency in the units, but the results and outcome were confined to them only. All the units in cluster have been operating in traditional conditions and most of the equipments in cluster were procured from the local suppliers, who are fabricating / manufacturing the equipments on basis of their age old expertise / technology.

These units are using various types of raw material such as Sulphuric acid, Hydrochloric acid, Acetylic acid, Chlorine gas, Benzene, Sodium nitrate, Ethylene, Ammonia, Disulphonic-acid, Copper, Chlorine, Ammonia and Potassium sulphate etc, The nature of raw material depends on their final product manufactured in the unit. All these raw materials are being procured from local suppliers/traders or bought from neighboring states. There are various types of chemical products manufacturing in cluster, few of them are DASDA, Alpha & Beta Pigment, Reactive dyes, Acid dyes, and direct dyes. In fact majority of the chemical units in these clusters manufacture two or three different types of chemical related products as per the market requirements.

1.1.1 Existing production process

The main production process used in chemical industry which is followed in the entire cluster with minor changes according to the requirements is shown in Figure 1.1 below:

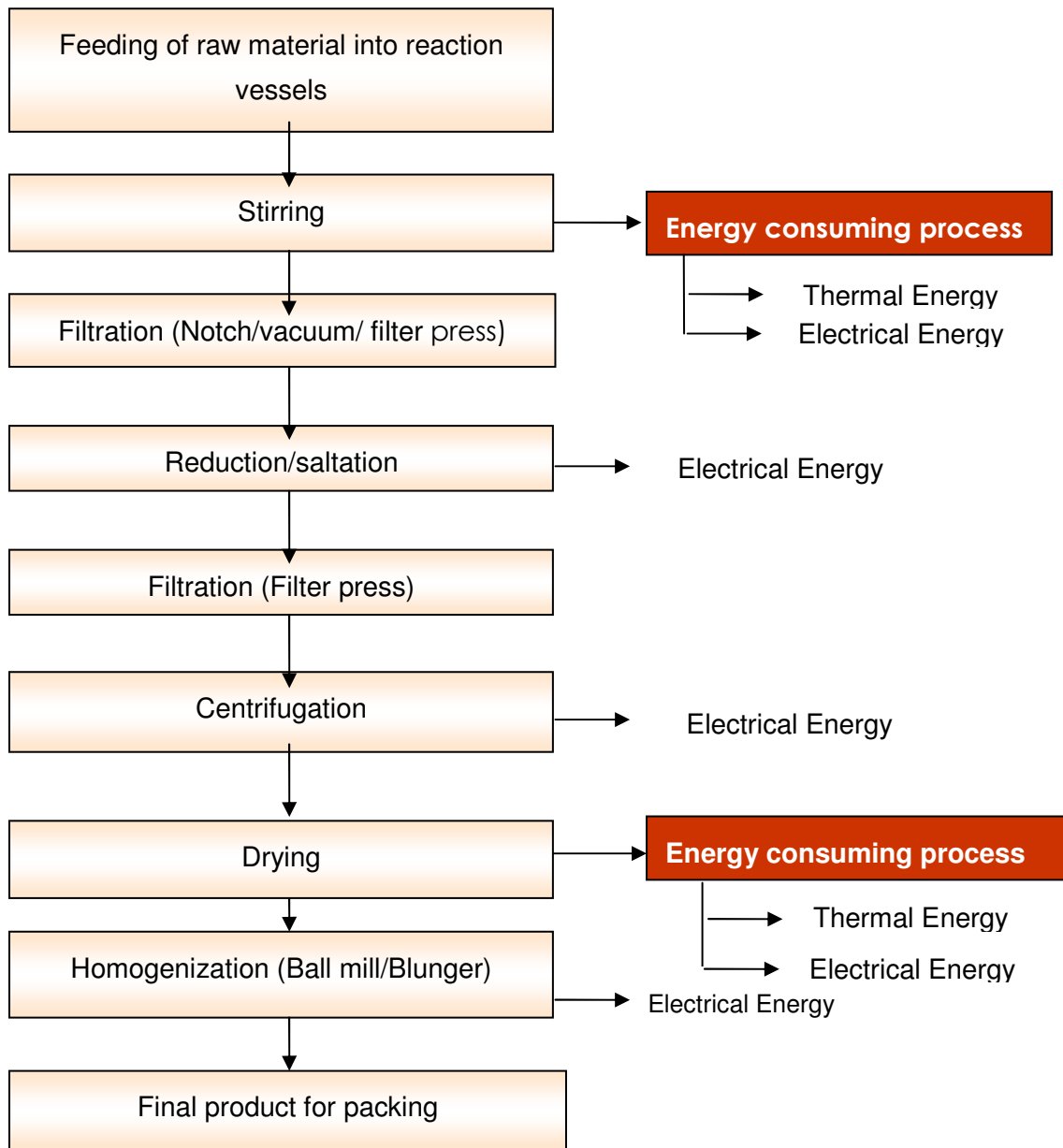

Figure 1.1: Process flow chart

The production process as depicted in the above chart is typical to almost all the chemical units in the Ahmadabad chemical cluster. However, depending on the final product, quality of final product and the attributes of the raw material, the above stated process flow is altered to suit the requirement of the unit.

1.2 Energy Performance in Ahmadabad chemical cluster

Majority of the industries located in Ahmedabad are engaged in manufacturing of different types of chemicals. Different chemical units in the Ahmedabad chemical cluster is using

the different types of energy sources including electricity and fuels such as wood, natural gas, biomass & coal depending on technology, process requirement, availability, economic and safety point of view. There are two forms of energy used in manufacturing of chemicals in typical chemical units in Ahmedabad cluster; electrical and thermal energy. Electrical energy is being used in operation of equipment & other electrical utilities and thermal energy is being used in process and drying applications. Energy cost is representing around 10-15 percent of manufacturing cost in a typical manufacturing unit, out of which thermal energy costs around 60 percent of the total energy cost and remaining accounts for electrical energy. In majority of the units in the Ahmedabad chemical cluster wood is used for thermal energy generation due to its easy availability at economical cost.

Annual energy consumption and average production of a typical chemical manufacturing unit are given in Table 1.1 below:

Table 1.1 Annual Energy consumption and production

S.No	Particular	Unit	Value
1	Electricity consumption	kWh	130000
2	Wood consumption	MT	350
3	Production	MT	110

1.2.1 Specific energy consumption

Specific electrical and thermal energy consumption in chemical unit is varying on the final product manufactured in that unit. Specific electrical and thermal energy consumption in a typical chemical is shown in Table 1.2 below:

Table 1.2 Specific energy consumption of a typical unit

S.No.	Particular	Unit	Value
1	Electricity	kWh/kg of product	1.2
2	Fuel	Kg of wood/kg of product	3.0

1.3 Identification of existing technology/ equipment

1.3.1 Description of equipment

During Energy use and technology audit studies in various chemical industries in Ahmedabad chemical cluster, it was observed that most of the chemical units are using inefficient hot air generator for generation of hot air and it is found that the efficiencies of the existing hot air generator is abysmally low. Detail specification and performances of

various hot air generators in Ahmadabad chemical units are evaluated and analyzed and same is presented in Annexure 1.



Figure1.2 Hot air generator operations at a chemical industry

From energy use and technology gap audit studies in various chemical units of Ahmadabad chemical cluster, the following were observed/ identified:

- Energy efficiency improvement opportunities
- Environment and safety improvement of workers
- Design flaws in the conventional hot air generator
- Operational & maintenance practices in conventional hot air generator

1.3.2 Technical gap in conventional wood fired HAG

Technology gaps/design flaws in conventional wood fired hot air generator system are identified and described below in detail

➤ Poor natural draught system

Draught is the most important factor in efficient fuel combustion. The conventional hot air generator system operates on natural draught system. The poor design of natural draught system in conventional hot air generator leads to inefficient fuel combustion.

➤ Poor design of ash pit and combustion system

The grate area of the hot air generator and ash pit below combustion chamber adds to overall resistance to draught system, this makes air flow through the grate more difficult. Due to lack of sufficient combustion of air in the combustion chamber, partial or improper combustion of fuel takes place in the existing hot air generators.

➤ **Poor heat transfer efficiency**

Heat transfer between the flue gas and air occurs in the air heating chamber in hot air generator. Due to poor heat transfer area and short time contact between flue gas and hot air leads to poor heat transfer, this further leads to inefficiency of the hot air generator system.

➤ **Heat loss from charging door**

The charging door remains more or less open during the entire operation due to various reasons; those are human error and non-compatibility of wood logs in combustion chamber. Grate / combustion chamber is not designed to accommodate wood log size and vice versa.

➤ **No control on fuel firing**

In conventional hot air generator there is no fuel firing control in combustion chamber and also proper air flow and pressure rating on blowers are not ensured

➤ **Poor insulation on HAG**

In conventional hot air generator insulation provided is not appropriate as per the temperature profile of the hot air circulated in the duct.

➤ **Temperature overshoots in combustion chamber**

There is no temperature control of hot air in hot air generator. Sometimes it causes temperature overshoot of hot air, which affects the quality of drying material.

From the aforesaid, it is evident that conventional hot air generator has poor performance in terms of energy, environment and social considerations. Existing wood fired hot air generator installed in most of the chemical units has poor energy efficiency, generates more GHG (Green House Gasses) into the environment and also has poor safety in operation. Due to the same it is urgently required to upgrade conventional hot air generator with energy efficient gas fired hot air generator.

1.3.3 Specification of existing system

Detailed technical specification of existing system is presented in Table 1.3 below:

Table 1.3 Specification of existing hot air generator

S.No.	Details	Units	Value
1	Capacity of hot air generator	kCal/hr	NA
DIMENSIONAL DETAILS			
2	Diameter of hot air generator	In	18
3	Height of combustion chamber	In	14
4	Height of hot air generator	In	99

5	Number of flue gas paths	Nos.	Single
6	Fuel used	type	Wood
7	Diameter of inlet pipe to hot air generator	In	4
8	Number & diameter of pipes in inside the hot air generator	Nos. & in	8 pipes of diameter 3 inches & 16 pipes of diameter 2 inches
9	Height of pipes inside HAG	In	65
10	Normal size of wood lags in HAG	In *In	18*5
11	Area of door openings in HAG	In *In	18*18
12	Type of draught system	-	Natural
14	Distance between in HAG and tray dryer	In	180
15	Diameter of hot air transfer pipe to tray dryer	In	8
INSULATION DETAILS OF HOT AIR TRANSFER PIPE			
16	Type of insulation of HAG transfer pipe		Glass wool
17	Thickness of insulation	In	2
18	FD fan control mechanism		Yes (Damper control)
19	Percentage opening of damper in ID fan	%age	45
20	Type of insulation in hot air generator		No insulation
21	Thickness of insulation in HAG		NA

1.3.4 Role in the process

Function of hot air generator in chemical units is to generate hot air to dry chemicals in different types of dryers. It is evident that drying is one of the major energy and time consuming process in the overall manufacturing process of chemical units. Apart from the energy and time, final product quality depends on quality of drying.

1.3.5 Need for up gradation of existing equipment

The drying cost is one of the major costs in the overall production process of chemical units' works out to be Rs. 3 per kg, this is approximately 30% of overall energy cost. Apart from the energy cost, drying time is one of the major issues in overall production process of chemical units, in typical chemical industry this would be around 52 hours.

The existing installed conventional hot air generator has poor efficiency of say around 32%, which leads to large GHGs emissions and also poses safety hazards in operation. Due to all the above mentioned factors, it is needed to change the conventional hot air generator with energy efficient gas fired hot air generator having efficiency 70%.

Advantages of replacing the conventional hot air generator with Energy Efficient gas fired hot air generator are:

- Reduction in wood consumption
- Improved productivity
- Reduction in production cost
- Improves environment and better compliance with environmental regulations
- Improves the efficiency of unit
- Reduction in GHGs emissions

1.4 Baseline energy consumption of existing equipment

Energy consumption in hot air generator would depend on the following:

- Drying temperature , which depends on product under manufacturing
- Climate conditions
- Operational & maintenance practices in hot air generator
- Quality & contents of wood

Energy use and technology audit studies were conducted in various units of Ahmadabad chemical cluster to establish the baseline energy consumption of hot air generator and the reports are given in Annexure-1.

1.4.1 Design and operating parameters

Major operating parameters to improve hot air generator performance are:

- Heat transfer area
- Contact time between flue gas and air
- Combustion system
- Insulation system
- Reducing the resistance in draught system
- Air flow
- Temperature of flue gasses.

Average wood consumption of hot air generator in typical chemical industry in Ahmadabad chemical cluster is 36 kg/hr and annual average wood energy consumption is around 130 tonnes per annum. Further, complete design and operating parameters are presented at Annexure 1.

1.4.2 Specific fuel consumption in existing system

Fuel consumption of typical wood fired hot air generator of adequate capacity to supply 1794 kg/hr hot air at 112 °C to one 200 trays dryer capacity is around 36 kg/hr. Performance of various hot air generators was evaluated and same is presented in Annexure 1.

1.4.3 Energy audit methodology

Following methodologies were adopted to evaluate the performance of existing wood fired hot air generator and presented in Figure 1.3 below:

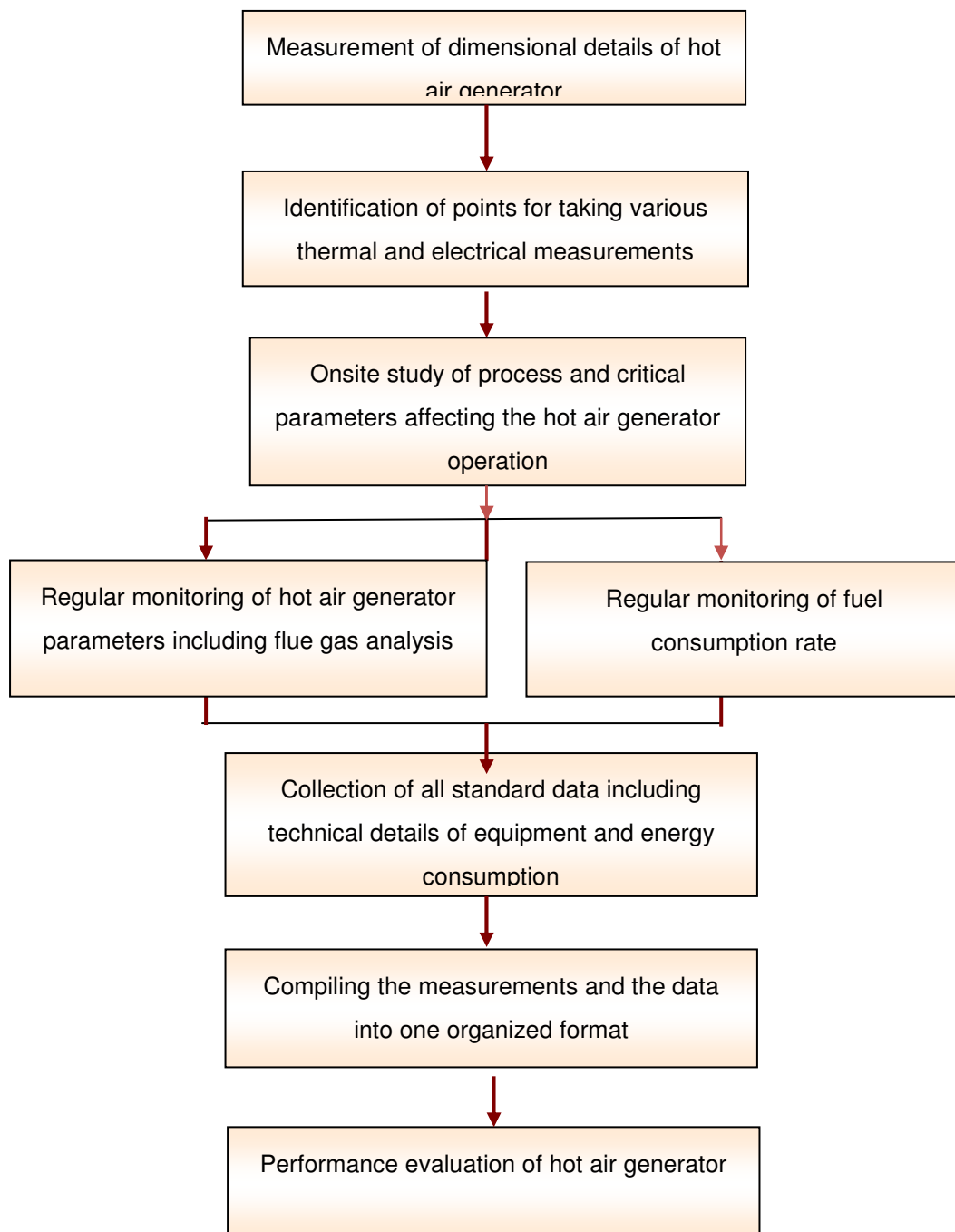

Figure1.3: Energy audit methodology

1.5 Barriers in adoption of proposed technology/equipment

The processes to do with technology and innovations in SMEs are different from those that take place in the context of the large firm. Technology in the SME sector has an increasingly complex or combinative characters as most of the SMEs units of the cluster are regarded for their labor intensive nature and the capability to work with local resources. In the past, SME entrepreneurs have laid more stress on technology to reduce the initial cost of plant & machineries. Major barriers in up-gradation of technology in the cluster are non availability of appropriate technology; distrust on technology supplier, lack of information/ awareness about the energy efficient technologies / equipments / processes among SMEs, which prevents them from adopting the same. Further non availability of skilled manpower and exorbitant cost of new technologies are perceived as barriers. Details of the other barriers in the implementation of energy efficient technologies/equipments in the Ahmadabad chemical cluster are given in the sections below:

1.5.1 Technological Barrier

Majority of the Chemical units entrepreneurs in Ahmedabad chemical cluster do not have any in depth technical expertise and knowledge on energy efficiency, and are dependent on local technology suppliers or service companies, which normally also rely on established and commonly used technology. One of the main barriers that prevents implementation of energy efficiency measures/technology up gradation projects in the Ahmedabad Chemical cluster are lack of awareness and information on the energy efficiency & energy efficient technologies. Most of chemical units in Ahmedabad chemical cluster have been established several years ago when energy efficiency was not important issue for the operation of a plant and therefore operating with outdated technology and low end technologies. Since around 15-20 years same technologies in various processes/utilities are continuing in most of the chemical industries in Ahmedabad Chemical cluster.

Core business of the SME owners is focused on uninterrupted production of the plant by conducting necessary repair work at lowest costs, than on investing in new technology. From the point of view of the operators the direct effect on income from a constant or increased production is much more important for the economic viability of the plant, than benefits in form of future savings due to efficiency measures. Maintaining the equipment requires additional efforts, organizational capacity and technical know-how not related to

the core business, all together resulting in additional costs. Therefore, even if they were aware of the benefits many chemical unit owners are shied away from such measures or investments. This short term view is strongly influenced by uncertainties described under the barrier of limited financial resources. Investments in replacing single still operational equipment are therefore seen as a rather unnecessary expenditure, and short-term planning has higher priority than sustainable long-term issues.

As the majority of the Entrepreneurs in cluster are not aware of the energy losses in the plant, there may be a strong feeling that the energy efficiency initiatives in manufacturing facility can have a cascading or domino effect of failure in critical production areas directly or indirectly connected if the intended performance of the replaced / retrofitted equipment falls below design values.

There is a strong feeling with the owners, that energy efficiency initiatives is a challenge to take the risk of such as business interruption due to production loss against the drive to save energy. These are however can be overcome by motivating them to attend the awareness programs and detailed report on the benefits of the measures identified and cost benefit analysis. Further, sourcing of expertise on maintenance service provider or training by the equipment supplier will definitely overcome the barriers.

1.5.2 Financial Barrier

Significant amount of investment is not commonly seen in SME industry sectors in India. Further, from the business perspective for any industry owner, it is more viable, assured and convenient to invest on project expansion for improving the production capacity or quality, rather than make piecemeal investment in retrofit and replace options for energy savings. Investment returns on large capacity addition or technology adoption shows up prominently in terms of savings and helps in benchmarking operations. Further, there is a strong feeling among the industry owners that, energy conservation-initiatives of replacement and retrofit nature is not a common practice as it involves large capital investment against low returns. In view of this and given the limited financial strength of the chemical units it is clear that the industry owners would not have taken up the risks and invest in energy efficiency measures.

1.5.3 Skilled manpower

The availability of the skilled manpower in the industry is one of the major barriers in the Ahmedabad chemical cluster. Though, the skilled manpower is available in the cluster, they are not aware of the energy conservation and efficiency and its importance, their prime responsibility is for zero machine down time and uninterrupted production as per the targets set by the management. Specialized training with the local service providers for

better operation and maintenance of the equipments, importance of the energy and its use will create awareness among workforce and these programs to be organized with the equipment suppliers.

2 IMPLEMENTATION OF PROPOSED TECHNOLOGY/EQUIPMENT

2.1 Description of proposed equipment

Proposed energy efficient gas fired hot air generator operates on the force draught system with controlled fuel combustion system. Improved grate area, this will reduce the resistance to the draught system and reduced the radiation loses from the combustion chamber. This system has three pass design compared to single pass design in conventional hot air generator system, which improves the heat transfer rate and increase time of contact, this automatically lead to improved heat transfer efficiency between hot flue gas and air. Due to above mentioned advantages leads to improved drying air temperature; this automatically reduces drying time.

2.1.1 Comparison of conventional HAG with energy efficient gas fired HAG

Technical, economic, Environmental, safety aspects of conventional wood fired hot air generator and energy efficient gas fired hot air generator are compared on life cycle of equipment, and same is presented in Table 2.1 below:

Table 2.1 Comparison of conventional equipment and proposed equipment

S. No	Details	Conventional hot air generator	Energy efficient Gas fired hot air generator
1	Fuel consumption	High	Low
2	Environment pollution	High (partial combustion & more fuel consumption)	Low (Complete combustion & less fuel consumption)
3	Safety of workers	Poor	Good
4	Maintenance	High	Low
5	Operational cost	High	Low
6	Availability of local supplier	Yes	Yes
Technical comparison			
7	Draught system	Natural	Forced
8	Fuel combustion	Partial	Complete
9	Control of fuel combustion	No	Yes
10	Temperature monitoring & control	No	Yes
11	Radiation losses	More	Less
12	Heat transfer between hot gasses and cold air	Less (Single path flue gas);	More (Three path flue gas)

From the above table it is clear that Energy efficient gas fired hot air generator has significant advantages in Energy, Environmental, Economic & safety aspects over the conventional wood fired hot air generators. It is therefore, justifiable to install energy efficient gas fired hot air generator in place of conventional wood fired hot air generator.

2.1.2 Equipment specification

Complete information about the new equipment along with specification is placed at Annexure 8.

2.1.3 Suitability over existing system

The proposed equipment is completely replacing the existing system and suitable with the existing process.

2.1.4 Superiority over existing system

The new system has better controlled fuel combustion than existing system and hence would yield better result in productivity.

2.1.5 Technical specifications

Design specifications of proposed Energy Efficient hot air generator is presented in Table 2.2 below:

Table 2.2 Technical specifications

S.No	Details	Units	Value
1	Name of equipment	NA	Gas fired HAG
2	Model	NA	AHA-300-G
3	Capacity	kCal/hr	30,000
4	Blower capacity	hp	2
5	Fuel used	NA	Gas
6	Fuel consumption	m ³ /hr	4.5
7	Total connected electrical load	hp	2.25
8	Electric supply	NA	AC 3 phase, 415V, 50 Hz
9	Hot air pipe outlet dimensions	in*in	9*9
10	Diameter of flue gas outlet	In	8
11	Air temperature of outlet	o C	150 (Max)

Scope of supply under the model of AHA-300-G gas fired hot air generator is given in Annexure 8.

2.1.6 Availability of proposed equipment

The equipment identified for implementation is available locally and are indigenously produced. The technology/ equipments will be procured from local equipment suppliers. The proposed equipment is locally manufactured by well known vendor of the Ahmedabad chemical cluster.

The equipment identified is available in the state of Gujarat (Ahmedabad) and implemented successfully in few units in cluster. The investment required for

implementation of the identified measures has good financial returns hence the proposed measure is technically and financially viable.

2.1.7 Equipment providers

Technology/service provider selected for implementation of the proposed energy efficiency project is having about 40 years of experience in implementation of energy efficiency projects. This technology/service provider is having in house R&D team to develop the new products, which are energy & eco friendly. Recommended supplier has the trust in cluster on products developed by them. Details of equipment suppliers are furnished in Annexure 7.

2.1.8 Terms and conditions in sales of Energy efficient HAG

The technology/service provider will provide performance guarantee for the products supplied and warranty for a period of one year for any manufacturing defects. The terms of sales from the proposed supplier is given at Annexure 8.

2.2 Process down time during implementation

The process down time for replacement of conventional hot air generator with energy efficient gas fired hot air generator is estimated to be one week. The implementation can be taken up during weekly holiday, or other holidays, so that the process down time can be reduced / minimized.

2.3 Suitable unit for proposed equipment

Based on the observations of energy use and technology audit studies it is evident that that proposed energy efficient gas fired hot air generator is having capacity of 30,000 kCal/hr is suitable for units having the tray dryer capacity of 200 trays.

3 ECONOMIC BENEFITS OF ENERGY EFFICIENT HOT AIR GENERATOR

Energy use and technology audit studies were conducted in various units of the Ahmadabad chemical cluster to evaluate the performance of existing hot air generator, technical gaps in existing hot air generator and analyzed energy, economic, environmental and social advantages of Energy Efficient Gas Fired Hot Air Generator over conventional wood fired hot air generator.

3.1 Energy & monetary benefits

3.1.1 Fuel Saving

From Energy use and technology audit studies it was observed that energy consumption of hot air generator depends on the number of tray dryers operating on a particular hot air generator and their temperature. Analysis of average wood consumption in conventional hot air generator was carried out from various energy use and technology audit studies in chemical units of the Ahmadabad chemical cluster; which works out to 36 kg/hr. Gas consumption in proposed furnace is 4.15 Nm³/hr. Hence, total wood consumption in existing generator which is about 130 tons per year will be displaced by 14940 Nm³ of LNG per year in energy efficient hot air generator.

3.1.2 Electricity saving

Project implementation will not save electricity while its implementation will increase electricity consumption of about 6040 kWh per year.

3.1.2 Monetary benefit

Annual monetary savings of implementation of energy efficient gas fired hot air generator in place of conventional hot air generator is thus ₹ 0.76 lakh per annum. Details of monetary saving calculation are furnished at Annexure 3.

3.2 Environmental benefits

3.2.1 Reduction of deforestation

Most of units of the cluster are using the non renewable wood for hot air generation; by installing the proposed energy efficient gas fired hot air generator in place of conventional wood fired hot air generator will replace non renewable fuel like wood, which will automatically reduce the deforestation.

3.2.2 GHG emission reductions

Fuel used in proposed energy efficient hot air generator is greener than fuel used in conventional hot air generator; therefore it automatically leads to reduction of GHG emissions leads to improved environment and better compliance with environmental

regulations and makes the project eligible for carbon benefit under Clean Development Mechanism [CDM].

3.2.3 CD Mability of the project

The proposed project saves about 130 tonne of wood per year for one hot air generator. This roughly corresponds to 123 tonnes of CO₂ emission reduction and use of LNG in place of wood for the same capacity will generate 30 tonnes of CO₂. This corresponds to 93 tonnes of CO₂ emission reduction. Considering at cluster level 200 units install the technology the total savings would be about 18,600 CERs per annum which can be a suitably sized small scale CDM project.

3.3 Social benefits

3.3.1 Impact on working environment

Replacement of conventional hot air generators with energy efficient gas fired hot air generators will improve the working condition & safety of workers.

3.3.2 Impact on manpower skills

Proposed energy efficient hot air generator components are procured from other companies and which will generate additional employment during installation and commissioning. Further, the training provided by equipment suppliers will improve the technical skill sets of manpower which will lead to their capacity building and well being.

3.3.3 Impact on wages/emoluments

The awareness created amongst worker and training imparted during implementation of the energy efficient technology project is expected to indirectly increase the wages of the workers as it improves their technical skills of operation and maintenance of equipments. Further, the remuneration will improve in the market or in other companies for the work force.

3.4 Other benefits (If any)

3.4.1 Productivity improvements

Due to improved design of gas fired hot air generator the productivity will increase as the drying time of chemicals gets reduced. As the drying is one of major time consuming operation, its reduction will improve productivity of chemical units of the Ahmadabad chemical cluster.

3.4.2 Quality improvements

Most of the chemicals manufactured by the Ahmadabad chemical cluster units are temperature sensitive. As inbuilt design of automatic temperature control system in energy

efficient gas fired hot air generator controls the temperature of hot air in tray dryers, this will automatically improve the quality of material produced.

3.4.3 Easy operation& maintenance

The energy efficient gas fired hot air generator is designed in such a way that it is easier for the unit to carry out regular maintenance of the hot air generator.

4 ECONOMICS & IMPLEMENTATION OF ENERGY EFFICIENT HAG

4.1 Cost of project implementation

4.1.1 Equipment cost

Technical and financial quotations of proposed energy efficient gas fired hot air generator are collected from reputed vendors. Cost of new equipment having capacity of 30,000 kCal per hour is ₹ 2.25 lakh only as per the quotation provided at Annexure 8.

4.1.2 Other cost

Erection & commissioning cost is ₹ 0.22 lakh only. Details of project cost are furnished in Table 4.1 below:

Table 4.1 Details of proposed equipment installation cost

S.No	Particular	Unit	Value
1	Equipment cost	₹ (in Lakh)	2.25
2	Erection & Commissioning cost	₹. (in Lakh)	0.22
3	Contingency cost	₹ (in Lakh)	0.03
4	Total cost	₹ (in Lakh)	2.50

4.2 Arrangement of funds

Proposed financing for the replacement of conventional hot air generator with energy efficient hot air generator is made considering a debt equity ratio of 3:1, which is normally allowed by financial institutions for financing energy efficiency projects. On the basis of debt equity ratio of 3:1 the promoter's contribution works out to 25% of the project cost and the balance would be term loan from the Bank / FIs.

4.2.1 Entrepreneurs contribution

Total cost (Equipment and erection& commissioning) of project works out to be ₹ 2.50 lakh. Out of which entrepreneur's contribution is 25%, which work out to be ₹ 0.63 lakh.

4.2.2 Loan amount

75% of the project cost would be available as term loan from the banks/financial institutions, which works out to be ₹ 1.88 lakh.

4.2.3 Terms & conditions of loan

The interest rate is considered at 10% which is SIDBI's rate of interest for energy efficient projects. The loan tenure is 7 years excluding initial moratorium period is 6 months from the date of first disbursement of loan.

4.3 Financial Indicators

4.3.1 Cash flow analysis

Profitability and cash flow statements have been worked out for a period of 10 years, being period, with in which the entire term loan would be repaid. The financials have been worked out on the basis of certain realistic assumptions, which are outlined below

- The project is expected to achieve monetary savings of ₹ 0.76 lakh per annum.
- The operational and Maintenance cost is estimated at 4% of cost of fixed assets with 5% increase every year to take care of escalations.
- The erection and commissioning charges is estimated at 10% of the total project cost for the plant and machinery
- Interest on term loan is estimated at 10%. The tenure of the loan is considered 5years and repayment starts after 6months from the first date of disbursement of loan in 60monthly installments.
- Depreciation is provided as per the rates provided in the companies Act.
- Income tax provision is made as per IT Act 1961.
- Based on the above assumptions, profitability and cash flow statements have been prepared.

4.3.2 Simple payback period

Simple payback period of replacing conventional hot air generator with energy efficient gas fired hot air generator is 3.29 year.

4.3.3 Net Present Value (NPV)

The Net present value of the investment on project is at @ 10.00% interest works out to ₹ 0.58 lakh.

4.3.4 Internal rate of return (IRR)

After tax Internal Rate of Return of the project is works out to be 15.80%. Thus the project is financially viable.

4.3.5 Return on Investment (ROI)

The average return on investment of the project activity works out at 20.13%.

Details of all the financial parameters for the replacement of conventional hot air generator with energy efficient gas fired hot air generator are presented in Table 4.1 below:

Table 4.1 Financial parameters of energy efficient hot air generator

S. No	Parameter	Unit	Value
1	Simple payback period	Years	3.29
2	NPV	₹ in lakh	0.58
3	IRR	%age	15.80
4	ROI	%age	20.13
5	DSCR	Ratio	1.40

4.4 Sensitivity analysis

In different situation fuel saving may increase or decrease on the basis of this scenarios a sensitivity analysis in realistic, pessimistic and optimistic scenario has been carried out which is as under

- Fuel saving increased by 5%
- Fuel saving decreased by 5%

Table 4.2 Sensitivity analysis

Particulars	IRR	NPV in lakh	ROI	DSCR
Normal	15.80%	0.58	20.13%	1.40
5% increase in fuel savings	23.65%	1.43	21.53%	1.79
5% decrease in fuel savings	6.77 %	0.30	17.47%	1.01

Assuming all provision and resource input would remain same during sensitivity analysis

4.5 Procurement and implementation schedule

Total time required for implementation of proposed project is about 13 weeks from the date of financial closure. Detailed procurement and implementation schedules are furnished at Annexure 6.

ANNEXURE**Annexure-1 Energy audit reports of conventional hot air generator****Energy audit report of hot air generator report at Unit-1**

Hot air generator is the one of the major energy consuming equipments in production process of chemicals in Unit-1. Detailed Performance assessment of the hot air generator at Unit-1 is presented in the tables below.

Hot air generator structure study

Vertical hot air generator is installed at Unit-1. The following table shows the dimensional details of hot air generator, heat transfer pipes, insulation details and other some important parameters of hot air generator:.

Details of hot air generator at Unit-1

S.No.	Details	Units	Value
1	Capacity of hot air generator	kCal/hr	NA
DIMENSIONAL DETAILS			
2	Diameter of hot air generator	In	18
3	Height of combustion chamber	In	14
4	Height of hot air generator	In	99
5	Number of flue gas paths	Nos.	Single
6	Fuel used	type	Wood
7	Diameter of inlet pipe to hot air generator	In	4
8	Number & diameter of pipes in inside the hot air generator	Nos. & in	8 pipes of diameter 3 inches & 16 pipes of diameter 2 inches
9	Height of pipes inside HAG	In	65
10	Normal size of wood lags in HAG	In *In	18*5
11	Area of door openings in HAG	In *In	18*18
12	Type of draught system	-	Natural
14	Distance between in HAG and tray dryer	In	180
15	Diameter of hot air transfer pipe to tray dryer	In	8
INSULATION DETAILS OF HOT AIR TRANSFER PIPE			
16	Type of insulation of HAG transfer pipe		Glass wool

17	Thickness of insulation	In	2
18	Capacity of ID fan	hp	NA
19	Capacity of FD fan	hp	5
20	Is there any flow control mechanism in FD fan		Yes (manual control of air by valve)
21	Percentage opening of damper in ID fan	%age	45
INSULATION DETAILS OF HOT AIR GENERATOR			
22	Type of insulation in hot air generator		No insulation
23	Thickness of insulation in HAG		NA

Efficiency of hot air generator was evaluated by following two methods

- Direct Method
- Indirect method

Both these methods require measuring of a number of operational parameters of the hot air generator. The indirect method has an advantage over the simpler direct method as various heat losses from hot air generator can be quantified and accounted. However, efficiency is calculated using both the methods and the results are presented along with the measured data in the following Tables

Measured parameters of hot air generator operation at Unit-1

S. No.	Particular	Unit	Value
1	Ambient air temperature (DBT)	°C	28.50
2	Relative humidity	% age	18.00
3	Moisture content in supply air	kg of moisture/kg of air	0.005
4	Density of air @ blower suction	kg/m ³	1.16
5	Average oxygen level in exhaust	% age	5.60
6	Average CO level in exhaust	ppm	1400.00
7	Average CO ₂ levels in exhaust	% age	4.90
8	Exit flue gas temperature	°C	321.00
9	Average surface temperature of hot air generator	°C	215.00
10	Radius of hot air generator	m	0.23
11	Height of hot air generator	m	2.54

12	Surface area of hot air generator	m ²	4.00
13	Average air velocity @ blower suction	m/sec	13.00
14	Area of blower suction	m ²	0.033
15	Volumetric flow of blower	m ³ /sec	0.43
16	Mass flow rate of air	kg/sec	0.50
		kg/hr	1794.59
17	Outlet temperature of hot air generator	°C	112.00
18	Temperature difference	°C	83.50
19	Wood consumption	kg/hr	36.00

Efficiency of hot air generator by direct method at Unit-1

S.No.	Particular	Unit	Details
1	Application of hot air generator		Hot air generation, drying the chemicals
2	Fuel input to hot air generator		Wood
3	Input air flow feeding rate	kg/hr	1794.59
4	Inlet temperature of air to HAG	°C	28.50
5	Outlet air temperature of HAG	°C	112.00
6	Specific heat capacity of air	kCal/kg-°C	0.24
7	GCV of wood	kCal/kg	2700
8	Heat output from hot air generator	kCal/hr	35963.58
9	Heat input of hot air generator	kCal/hr	97200.00
10	Direct efficiency of hot air generator	% age	37

Efficiency of hot air generator by indirect method at Unit-1

S. No.	Particular	Unit	Value
1	Measured O ₂ in flue gas	% age	5.60
2	Measured CO ₂ in flue gas	% age	4.90
3	Measured CO in flue gas	ppm	1400.00
4	Temperature of flue gas	°C	321.00

5	Excess air used for combustion	% age	37
6	Total air used for combustion	kg of air	15.18
7	Heat loss due to dry flue gas	% age	40.89
8	Heat loss due to moisture in fuel	% age	5.37
9	Heat loss due to hydrogen in fuel	% age	12.30
10	Heat loss due to moisture in air	% age	0.37
11	Heat loss due to co formation	% age	2.86
12	Heat loss due to radiation	% age	4.32
13	Heat loss in bottom ash	% age	1.58
14	Total losses	% age	67.69
15	Hot air generator efficiency	% age	32.31

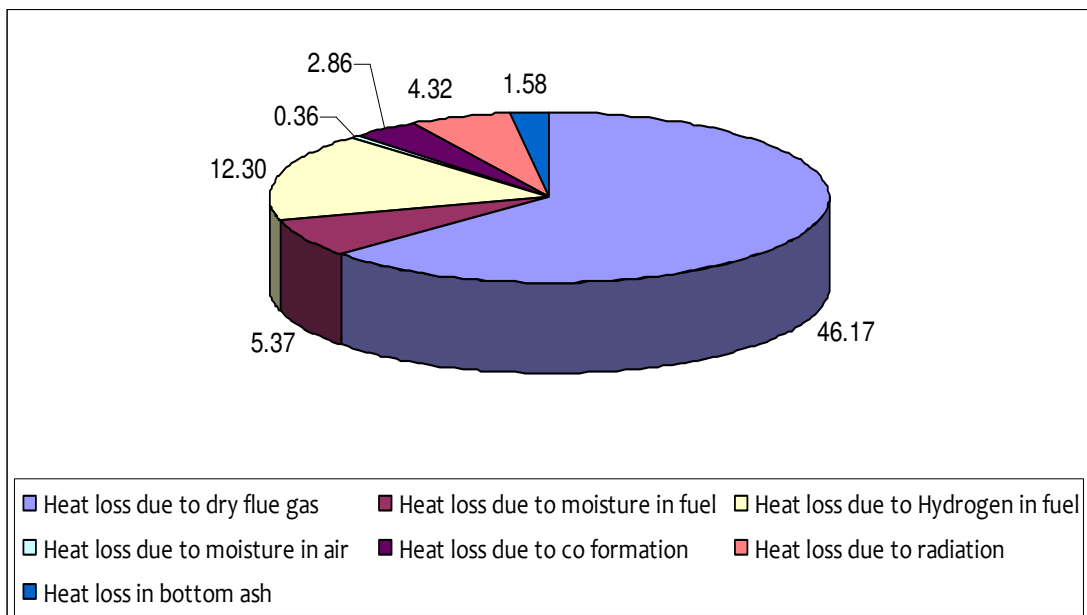

Percentage of various heat losses in hot air generator at Unit-1

Observations

- High radiation losses are observed in the Hot air generator and hot air transfer pipe, due to poor insulation of hot air generator and hot air transfer pipe.
- Heat losses are more in the charging door, because of continuous opening of charging door
- No temperature monitoring and control system is in operation

Hot air generator audit report of Unit-2

S.No.	Details	Units	Value
1	Capacity of hot air generator	kCal/hr	NA
DIMENSIONAL DETAILS			
2	Diameter of hot air generator	in	18
3	Height of combustion chamber	in	14
4	Height of hot air generator	in	99
5	Number of flue gas paths	Nos.	Single
6	Type of fuel used		Wood
7	Diameter of inlet pipe to hot air generator	In	4
8	Number & diameter of pipes in inside the hot air generator	Nos. & In	6 pipes of diameter 3 inches & 12 pipes of diameter 2 inches
9	Height of pipes inside HAG	In	65
10	Normal size of wood lags in HAG	In* In	18*5
11	Area of door openings in HAG	In* In	18*18
12	Type of draught system		Natural
14	Distance between in hot air generator and tray dryer	In	100
15	Diameter of the hot air transfer pipe to tray dryer	In	8
INSULATION DETAILS OF HOT AIR TRANSFER PIPE			
16	Type of insulation of HAG transfer pipe		Glass wool
17	Thickness of insulation	In	3
18	Capacity of ID fan	hp	NA
19	Capacity of FD fan	hp	5
20	Is there any flow control in FD fan		Yes
21	Percentage opening of damper in ID fan	% age	100
INSULATION DETAILS OF HOT AIR GENERATOR			
22	Type of insulation in hot air generator		Glass wool
23	Thickness of insulation in HAG	in	3

Measured parameters of hot air generator operation at Unit-2

S.No.	Particulars	Unit	Value
1	Ambient air temperature (DBT)	°C	27.30
2	Relative humidity	%	59.10
3	Moisture content in supply air	kg of moisture/kg of air	0.014
4	Density of blower suction air	kg/m ³	1.15
5	Average oxygen level in exhaust	% age	4.50
6	Average CO level in exhaust	ppm	2050.00
7	Average CO ₂ levels in exhaust	% age	5.10
8	Exit flue gas temperature	°C	295.00
9	Average surface temperature of HAG	°C	125.00
10	Radius of HAG	m	0.23
11	Height of HAG	m	2.79
12	Surface area of the HAG	m ²	4.36
13	Average air velocity at blower suction	m/sec	18.00
14	Area of blower suction	m ²	0.023
15	Volumetric flow of blower	m ³ /sec	0.41
16	Mass flow rate of air	kg/sec	0.48
17	Mass flow rate of air	kg/hr	1713.96
18	Outlet temperature of HAG	°C	122.00
19	Temperature difference of hot air and cold air	°C	94.70
20	Fuel consumption rate	kg/hr	42

Calculation of hot air generator efficiency by direct method at Unit-2

S.No	Particular	Unit	Details
1	Application of HAG		drying the chemicals
2	Fuel input to HAG		Wood
3	Input air flow feeding rate to HAG	kg/hr	1713.96

Gas Fired Hot Air Generator (30,000 kCal/hr)

4	Temperature of inlet air to HAG	°C	27.30
5	Outlet air temperature of HAG	°C	122.00
6	Specific heat of air	kCal/kg-°C	0.24
7	Heat output from HAG	kCal/hr	38954.88
8	Heat input to HAG	kCal/hr	113400.00
9	Direct efficiency of HAG	% age	34.35

Efficiency of hot air generator by indirect method at Unit-2

S.No.	Particulars	Units	Value
1	Measured O ₂ in flue gas	% age	4.50
2	Measured CO ₂ in flue gas	% age	5.10
3	Measured CO in flue gas	ppm	2050.00
4	Temperature of flue gas	°C	295.00
5	Excess air used for combustion	% age	27.27
6	Total air used for combustion	kg of air	14.60
7	Heat loss due to dry flue gas	% age	35.57
8	Heat loss due to moisture in fuel	% age	5.22
9	Heat loss due to Hydrogen in fuel	% age	11.74
10	Heat loss due to moisture in air	% age	0.92
11	Heat loss due to co formation	% age	3.98
12	Heat loss due to radiation	% age	4.75
13	Heat loss in bottom ash	% age	1.58
14	Total losses	% age	63.75
15	Hot air generator efficiency	% age	36.24

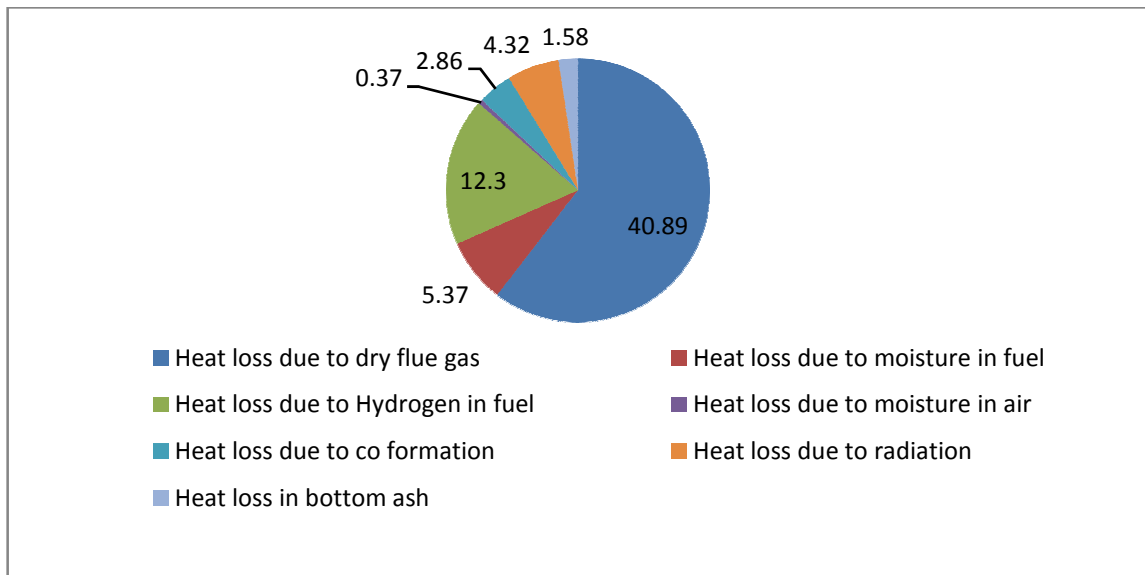

Percentage of various heat losses in hot air generator at Unit-2

Hot air generator energy audit report of Unit-3

Details of Hot air generator at Unit-3:

S.No.	Details	Units	Value
1	Capacity of HAG	kCal/hr	NA
2	Diameter of HAG	In	42
3	Height of combustion chamber	In	14
4	Height of HAG	In	99
5	Number of flue gas paths	Nos.	Single
6	Fuel used	Type	Wood
7	Diameter of inlet pipe to HAG	In	4
8	Number & diameter of pipes in inside the HAG	In	8 pipes of Dia 3 inches & 16 pipes of Dia 2 inches
9	Height of pipes inside HAG	In	65
10	Normal size of wood lags in HAG	In* In	18*5
11	Area of door openings in HAG	In* In	18*18
12	Draught system	Type	Natural
14	Distance between in HAG and tray dryer	In	150
15	Diameter of the hot air transfer pipe to tray dryer	In	8

INSULATION DETAILS OF HOT AIR TRANSFER PIPE			
16	Type of insulation of HAG transfer pipe		Glass wool
17	Thickness of insulation	In	3
18	Capacity of ID fan	hp	NA
19	Capacity of FD fan	hp	5
20	Flow control mechanism in FD fan		Yes (manual control of air)
21	Percentage opening of damper in ID fan	% age	70
INSULATION DETAILS OF HOT AIR GENERATOR			
22	Type of insulation in hot air generator		Glass wool
23	Thickness of insulation	In	3

Measured parameters of hot air generator at Unit-3

S.No.	Details	Units	Value
1	Ambient air temperature (DBT)	°C	28.50
2	Relative humidity	% age	18.00
3	Moisture content in supply air	kg of moisture/kg of air	0.005
4	Density of air @ blower suction	kg/m ³	1.16
5	Average O ₂ level in exhaust	% age	3.20
6	Average CO level in exhaust	ppm	2450.00
7	Average CO ₂ levels in exhaust	% age	4.50
8	Exit flue gas temperature	°C	249.00
9	Average surface temperature of hot air generator	°C	112.00
10	Radius of hot air generator	m	0.46
11	Height of hot air generator	m	2.79
12	Surface area of hot air generator	m ²	9.40
14	Average air velocity @ blower suction	m/sec	8.44
15	Area of blower suction	m ²	0.023

16	Volumetric flow of blower	m ³ /sec	0.19
17	Mass flow rate of air	kg/sec	0.23
18	Mass flow rate of air	kg/hr	812.04
19	Outlet temperature of hot air generator	°C	98.00
20	Temperature difference	°C	69.50
21	Wood consumption	kg/hr	22.00

Calculation of hot air generator efficiency by direct method at Unit-3

S.No.	Particular	Unit	Details
1	Application of HAG		Used in drying the chemicals
2	Fuel input to HAG		Wood
3	Input air flow feeding rate	kg/hr	812.04
4	Inlet temperature of air to HAG	°C	28.50
5	Outlet air temperature of HAG	°C	98.00
6	Specific heat of air	kCal/kg-°C	0.24
7	Heat output from HAG	kCal/hr	13544.16
8	Heat input of HAG	kCal/hr	59400.00
9	Direct efficiency of HAG	%	22.80

Calculation of hot air generator efficiency by indirect method at Unit-3

S.No.	Particulars	unit	Value
1	Measured O ₂ in flue gas	% age	3.20
2	Measured CO ₂ in flue gas	% age	4.50
3	Measured CO in flue gas	ppm	2450.00
4	Temperature of flue gas	°C	249.00
5	Excess air used for combustion	% age	17.98
6	Total air used for combustion	kg	14.00
7	Heat loss due to dry flue gas	% age	33.20
8	Heat loss due to moisture in fuel	% age	5.11
9	Heat loss due to Hydrogen in fuel	% age	11.73

10	Heat loss due to moisture in air	% age	0.25
11	Heat loss due to CO formation	% age	5.32
12	Heat loss due to radiation	% age	16.62
14	Heat loss in bottom ash	% age	1.58
15	Total losses	% age	73.80
16	Boiler Efficiency (Indirect Method)	% age	26.20

Percentages of various losses in hot air generator have been plotted graphically in the figure below. The following pie-chart represents the various losses in the hot air generator at Unit-3.

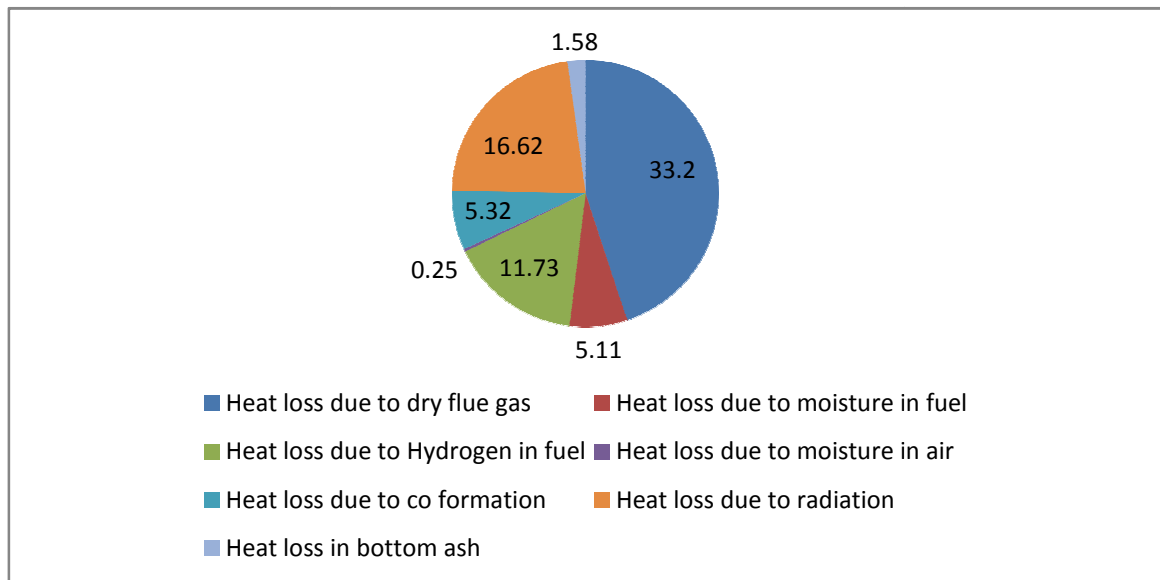

Percentage of various heat losses in hot air generator at Unit-3

Annexure 2 Process flow diagram

Process flow diagram of chemical industry in Ahmadabad Chemical cluster is furnished in figure below

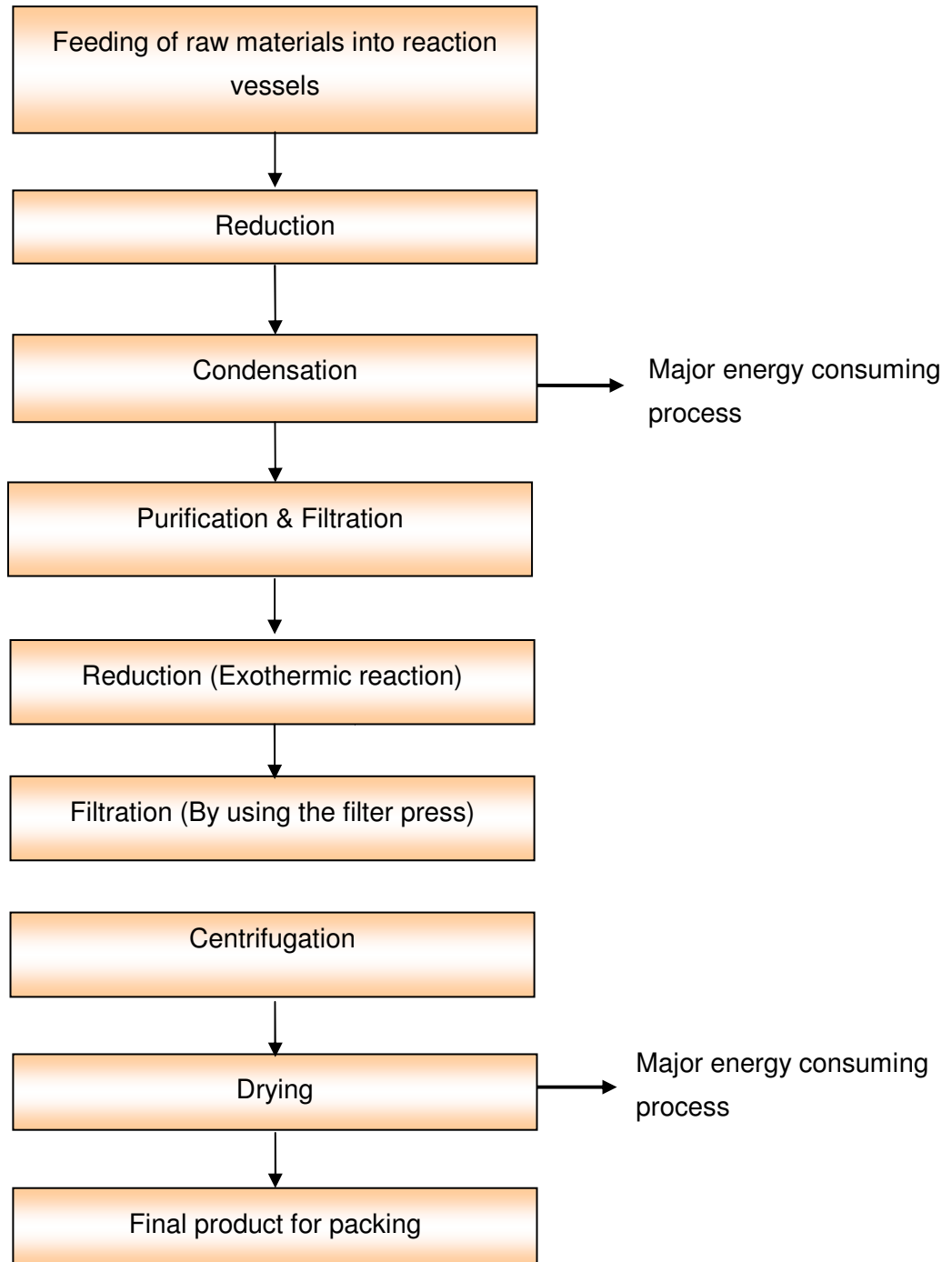

Annexure-3 Detailed technical assessment report

Most of the chemical industries in Ahmadabad chemical cluster are in unorganized sector with low engineering, limited technology innovation and poor R&D base as well as low level of human resource on knowledge of technology, operational skill etc. This sector also faces deficiencies such as the lack of access to technology and technology sharing and the inadequacies of strong organizational structure, professional attitude etc.

Comprehensive Study conducted at various chemical units in Ahmadabad Chemical cluster to assess the technology gap in different processes and utilities. Following technical gaps are observed during our study:

- The technology of the unit for some of the equipments installed is poor as compared to technologies available in market. Various technological gaps were identified in chemical units and these may be due to lack awareness on the technologies available, quantum of energy loss and its monetary benefit, lack of awareness among the workforce etc.
- There is a tremendous need for this cluster to modernize/upgrade its technology and adopt energy efficient technologies in some of their operational areas. Further, the management based on discussions, are interested in improve the efficiency of the plant by adopting this type of technology instead of going for retrofit options in the existing equipments.

The various factors which influence the management towards implementation of energy efficiency and energy conservation projects in chemical units in Ahmadabad Chemical cluster are:

- Energy efficiency and energy conservation is a low cost investment option which reduces energy consumption
- Low capital investment
- The energy efficiency improvement will enhance the plant management to be competitive in local and global markets by reducing production cost
- To conserve depleting fossil fuels
- The energy efficiency and conservation reduces GHG emissions because of low carbon dioxide and particulate emissions
- Energy efficiency and conservation is a viable strategy to meet future energy needs of the expanding plans in the industry
- The return on investment is attractive with lower pay back periods.

S.No	Parameter	Unit	Value
1	Present wood consumption of existing hot air generator	kg/hr	36
2	Total operating hours	hours	12
3	Operational days per annum	Days/annum	300
4	LNG consumption in new gas fired hot air generator	M ³ /hr	4.5
5	LNG consumption in new gas fired hot air generator	Nm ³ /hr	4.15
6	Cost of LNG	₹ / Nm ³	19
7	Cost of wood	₹ /kg	3
8	Annual wood consumption	kg/year	1,30,000
9	Annual gas consumption	Nm ³ /year	14,940
10	Total connected load	kW	1.67
11	Total electricity consumption	kWh/year	6040
12	Total monetary saving due to fuel change	₹ (In lakh)/year	1.06
13	Cost of electricity consumption @ 5 Rs. /kWh	₹ (In lakh)/year	0.30
14	Monetary benefit	₹in lakh	0.76
15	Total investment	₹in lakh	2.50
16	Simple payback period	Years	3.29

Annexure-4 Electrical & civil works drawing of energy efficient HAG

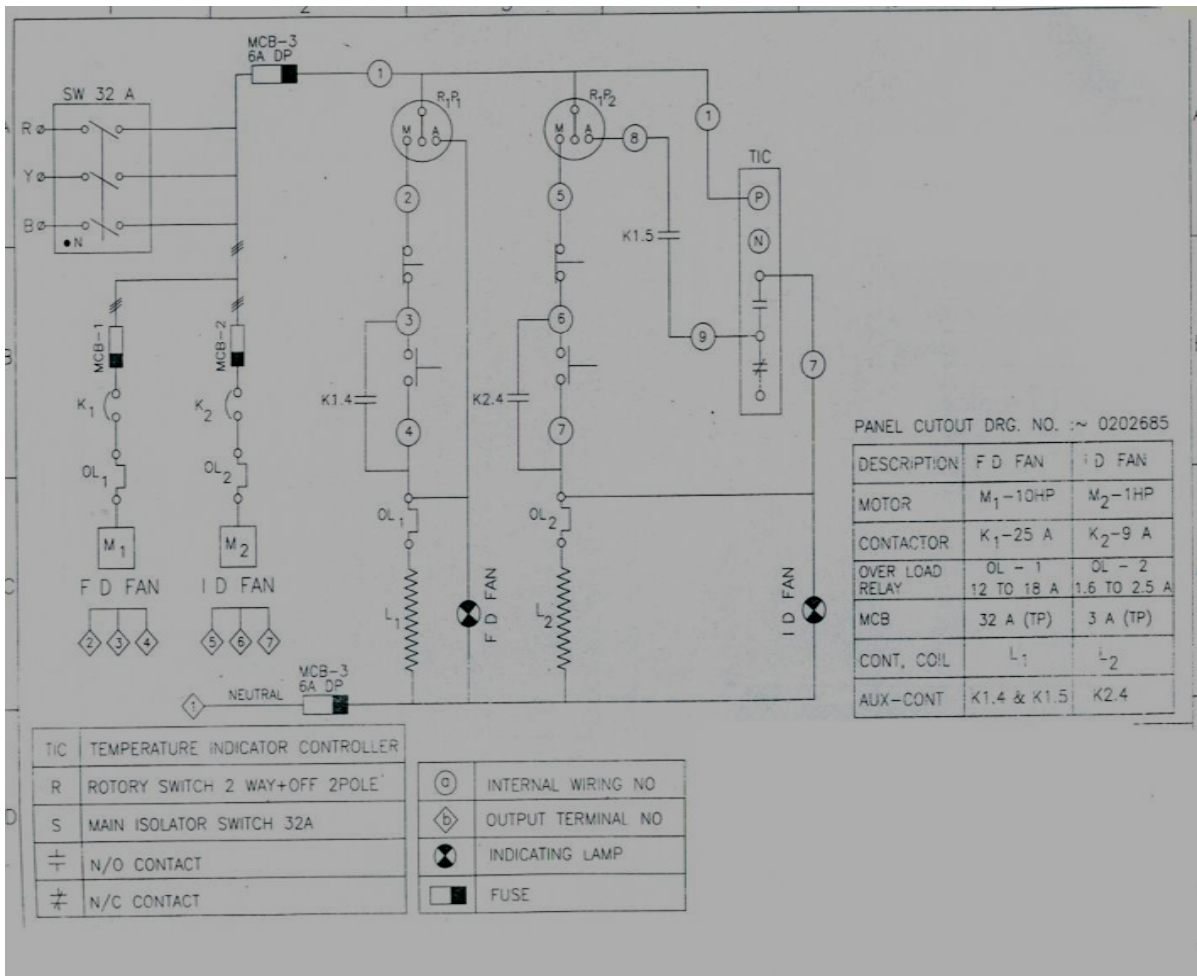

Front & side view of energy efficient gas fired hot air generator

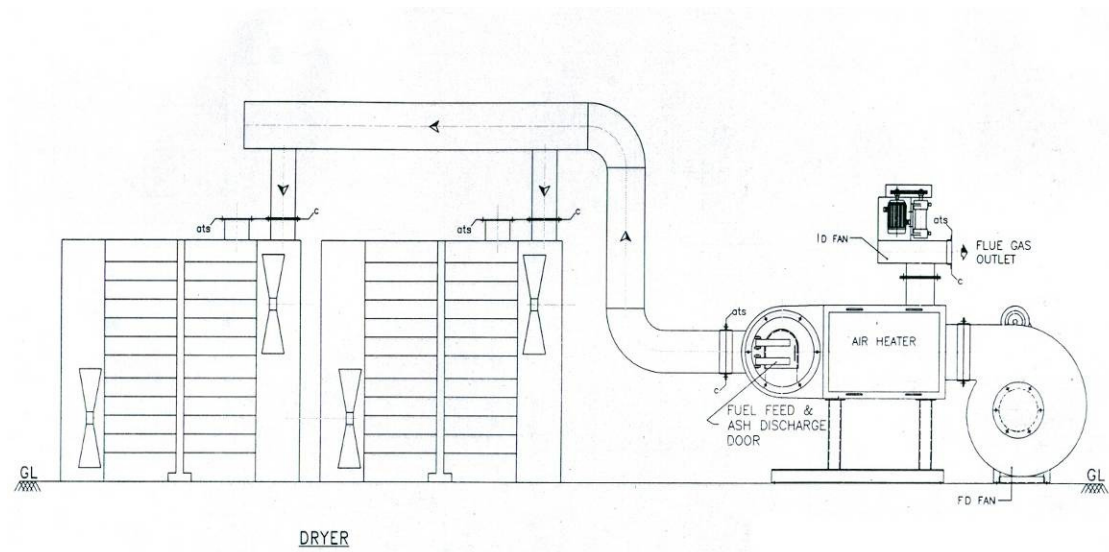
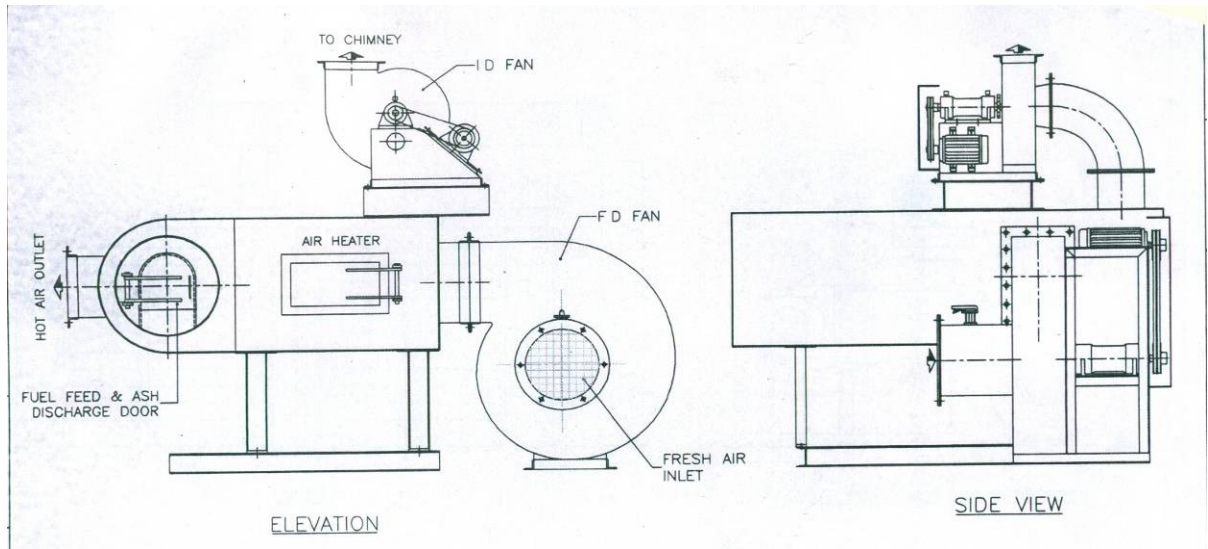

Annexure-5 Detailed cash flow evaluations of energy efficient HAG

Name of the Technology	Gas fired Hot Air Generator		
Rated Capacity	30,000k Cal/hr		
Details	Unit	Value	Basis
Installed Capacity	kCal/hr	30,000	Feasibility Study
No of working days	Days	300	Feasibility Study
Total operating Hours	Hrs.	12	Feasibility Study
Proposed Investment			
Cost of plant & Machinery	₹ (in lakh)	2.25	Feasibility Study
Erection & Commissioning (10% of plant machinery)	₹ (in lakh)	0.22	Feasibility Study
Other charges(Contingency)	₹ (in lakh)	0.03	Feasibility Study
Total Investment	₹ (in lakh)	2.50	Feasibility Study
Financing pattern			
Own Funds (Internal Accruals)	₹ (in lakh)	0.63	Feasibility Study
Loan Funds (Term Loan)	₹ (in lakh)	1.88	Feasibility Study
Loan Tenure	Years	7	Assumed
Moratorium Period	Months	6	Assumed
Repayment Period	Months	90	Assumed
Interest Rate	%	10.00	SIDBI Lending rate
Estimation of Costs			
O& M Costs	% (on Plant & Equip)	4.00	Feasibility Study
Annual Escalation	%	5.00	Feasibility Study
Estimation of Revenue			
Wood Consumption (in base scenario)	kg/hr	130000	-
Cost	₹ /Kg	3.00	-
LNG Consumption	Nm3/Year	14940	-
Cost	₹ /Nm3	19.00	-
Electricity consumption	kWh/Year	6040	-
Cost	₹ /kWh	5.00	Assumption
St. line Depreciation	%	5.28	Indian Companies Act
IT Depreciation	%	80.00	Income Tax Rules
Income Tax	%	33.99	Income Tax Act 2008-09

Estimation of Interest on term loan**Rs. (in lakh)**

Years	Opening Balance	Repayment	Closing Balance	Interest
1	1.88	0.06	1.82	0.22
2	1.82	0.12	1.70	0.18
3	1.70	0.16	1.54	0.16
4	1.54	0.24	1.30	0.14
5	1.30	0.28	1.02	0.12
6	1.02	0.32	0.70	0.09
7	0.70	0.48	0.22	0.05
8	0.22	0.22	0.00	0.01
		1.88		

WDV Depreciation

₹ (in lakh)

Particulars / years	1	2
Plant and Machinery		
Cost	2.50	0.50
Depreciation	2.00	0.40
WDV	0.50	0.10

Projected Profitability

₹ (in lakh)

Particulars / Years	1	2	3	4	5	6	7	8	9	10	Total
Revenue through Savings											
Fuel savings	0.76	0.76	0.76	0.76	0.76	0.76	0.76	0.76	0.76	0.76	7.59
Total Revenue (A)	0.76	0.76	0.76	0.76	0.76	0.76	0.76	0.76	0.76	0.76	7.59
Expenses											
O & M Expenses	0.10	0.11	0.11	0.12	0.12	0.13	0.13	0.14	0.15	0.16	1.26
Total Expenses (B)	0.10	0.11	0.11	0.12	0.12	0.13	0.13	0.14	0.15	0.16	1.26
PBDIT (A)-(B)	0.66	0.65	0.65	0.64	0.64	0.63	0.63	0.62	0.61	0.60	6.34
Interest	0.22	0.18	0.16	0.14	0.12	0.09	0.05	0.01	-	-	0.96
PBDT	0.44	0.48	0.49	0.50	0.52	0.54	0.58	0.61	0.61	0.60	5.37
Depreciation	0.13	0.13	0.13	0.13	0.13	0.13	0.13	0.13	0.13	0.13	1.32
PBT	0.31	0.35	0.35	0.37	0.39	0.41	0.45	0.48	0.48	0.47	4.05
Income tax	-	0.03	0.17	0.17	0.18	0.18	0.20	0.21	0.21	0.21	1.54
Profit after tax (PAT)	0.31	0.32	0.19	0.20	0.21	0.23	0.25	0.27	0.27	0.27	2.51

Computation of Tax

₹ (in lakh)

Particulars / Years	1	2	3	4	5	6	7	8	9	10
Profit before tax	0.31	0.35	0.35	0.37	0.39	0.41	0.45	0.48	0.48	0.47
Add: Book depreciation	0.13	0.13	0.13	0.13	0.13	0.13	0.13	0.13	0.13	0.13
Less: WDV depreciation	2.00	0.40	-	-	-	-	-	-	-	-
Taxable profit	(1.56)	0.08	0.49	0.50	0.52	0.54	0.58	0.61	0.61	0.60
Income Tax	-	0.03	0.17	0.17	0.18	0.18	0.20	0.21	0.21	0.21

Projected Balance Sheet

Particulars / Years	1	2	3	4	5	6	7	8	9	10
Liabilities										
Share Capital (D)	0.63	0.63	0.63	0.63	0.63	0.63	0.63	0.63	0.63	0.63
Reserves & Surplus (E)	0.31	0.63	0.82	1.02	1.23	1.45	1.70	1.97	2.25	2.51
Term Loans (F)	1.82	1.70	1.54	1.30	1.02	0.70	0.22	0.00	0.00	0.00
TOTAL LIABILITIES (D)+(E)+(F)	2.75	2.95	2.98	2.94	2.87	2.77	2.54	2.59	2.87	3.13
Assets										
Gross Fixed Assets	2.50	2.50	2.50	2.50	2.50	2.50	2.50	2.50	2.50	2.50
Less Accm. depreciation	0.13	0.26	0.40	0.53	0.66	0.79	0.92	1.06	1.19	1.32
Net Fixed Assets	2.37	2.24	2.10	1.97	1.84	1.71	1.58	1.44	1.31	1.18
Cash & Bank Balance	0.38	0.71	0.87	0.96	1.03	1.06	0.97	1.15	1.55	1.95
TOTAL ASSETS	2.75	2.95	2.98	2.94	2.87	2.77	2.54	2.59	2.87	3.13
Net Worth	0.93	1.25	1.44	1.64	1.85	2.08	2.33	2.60	2.87	3.14
Debt Equity Ratio	2.90	2.71	2.46	2.07	1.62	1.11	0.34	-0.01	-0.01	-0.01

Projected Cash Flow:

₹ (in lakh)

Particulars / Years	0	1	2	3	4	5	6	7	8	9	10
Sources											
Share Capital	0.63	-	-	-	-	-	-	-	-	-	-
Term Loan	1.88										
Profit After tax		0.31	0.32	0.19	0.20	0.21	0.23	0.25	0.27	0.27	0.27
Depreciation		0.13	0.13	0.13	0.13	0.13	0.13	0.13	0.13	0.13	0.13
Total Sources	2.50	0.44	0.45	0.32	0.33	0.34	0.36	0.38	0.40	0.40	0.40
Application											
Capital Expenditure	2.50										
Repayment Of Loan	-	0.06	0.12	0.16	0.24	0.28	0.32	0.48	0.22	-	-
Total Application	2.50	0.06	0.12	0.16	0.24	0.28	0.32	0.48	0.22	-	-
Net Surplus	-	0.38	0.33	0.16	0.09	0.06	0.04	(0.10)	0.18	0.40	0.40
Add: Opening Balance	-	-	0.38	0.71	0.87	0.96	1.03	1.06	0.97	1.15	1.55
Closing Balance	-	0.38	0.71	0.87	0.96	1.03	1.06	0.97	1.15	1.55	1.95

IRR

₹ (in lakh)

Particulars / months	0	1	2	3	4	5	6	7	8	9	10
Profit after Tax		0.31	0.32	0.19	0.20	0.21	0.23	0.25	0.27	0.27	0.27
Depreciation		0.13	0.13	0.13	0.13	0.13	0.13	0.13	0.13	0.13	0.13
Interest on Term Loan		0.22	0.18	0.16	0.14	0.12	0.09	0.05	0.01	-	-
Cash outflow	(2.50)	-	-	-	-	-	-	-	-	-	-
Net Cash flow	(2.50)	0.66	0.63	0.48	0.47	0.46	0.45	0.43	0.41	0.40	0.40
IRR	15.80%										

NPV

0.58

Break Even Point

Particulars / Years	1	2	3	4	5	6	7	8	9	10
Variable Expenses										
Oper. & Maintenance Exp (75%)	0.08	0.08	0.08	0.09	0.09	0.10	0.10	0.11	0.11	0.12
Sub Total (G)	0.08	0.08	0.08	0.09	0.09	0.10	0.10	0.11	0.11	0.12
Fixed Expenses										
Oper. & Maintenance Exp (25%)	0.03	0.03	0.03	0.03	0.03	0.03	0.03	0.04	0.04	0.04
Interest on Term Loan	0.22	0.18	0.16	0.14	0.12	0.09	0.05	0.01	0.00	0.00
Depreciation (H)	0.13	0.13	0.13	0.13	0.13	0.13	0.13	0.13	0.13	0.13
Sub Total (I)	0.38	0.33	0.32	0.30	0.28	0.25	0.21	0.17	0.17	0.17
Sales (J)	0.76	0.76	0.76	0.76	0.76	0.76	0.76	0.76	0.76	0.76
Contribution (K)	0.68	0.68	0.68	0.67	0.67	0.66	0.66	0.65	0.65	0.64
Break Even Point (L= G/I)	54.81%	49.11%	47.75%	45.13%	42.06%	38.20%	32.35%	26.58%	26.05%	26.56%
Cash Break Even {(I)-(H)}	35.52%	29.72%	28.24%	25.50%	22.31%	18.31%	12.31%	6.39%	5.69%	6.03%
Break Even Sales (J)*(L)	0.42	0.37	0.36	0.34	0.32	0.29	0.25	0.20	0.20	0.20

Return on Investment

₹ (in lakh)

Particulars / Years	1	2	3	4	5	6	7	8	9	10	Total
Net Profit Before Taxes	0.31	0.35	0.35	0.37	0.39	0.41	0.45	0.48	0.48	0.47	4.05
Net Worth	0.93	1.25	1.44	1.64	1.85	2.08	2.33	2.60	2.87	3.14	20.14
											20.13%

Debt Service Coverage Ratio

₹ (in lakh)

Particulars / Years	1	2	3	4	5	6	7	8	9	10	Total
Cash Inflow											
Profit after Tax	0.31	0.32	0.19	0.20	0.21	0.23	0.25	0.27	0.27	1.97	0.31
Depreciation	0.13	0.13	0.13	0.13	0.13	0.13	0.13	0.13	0.13	1.06	0.13
Interest on Term Loan	0.22	0.18	0.16	0.14	0.12	0.09	0.05	0.01	0.00	0.96	0.22
Total (M)	0.66	0.63	0.48	0.47	0.46	0.45	0.43	0.41	0.40	3.99	0.66

DEBT

Interest on Term Loan	0.22	0.18	0.16	0.14	0.12	0.09	0.05	0.01	0.00	0.00	0.96
Repayment of Term Loan	0.06	0.12	0.16	0.24	0.28	0.32	0.48	0.22	0.00	0.00	1.88
Total (N)	0.28	0.30	0.32	0.38	0.40	0.41	0.53	0.23	0.00	0.00	2.84
Average DSCR (M/N)	1.40										

Annexure-6 Details of procurement and implementation plan

Procurement and implementation schedule of energy efficient hot air generator in place of conventional hot air generator are presented below.

Activity	Weeks												
	1	2	3	4	5	6	7	8	9	10	11	12	13
Energy data reconfirmation	■												
Technical discussion & finalization	■	■											
Collection of vendor quotes			■										
Order placement				■									
Material receipt				■	■	■	■	■	■	■			
Installation & Commissioning											■		
Measurement of savings											■	■	
Certification of savings													■

Annexure-7 Details of equipment and service providers

Name of company	Aero Therm Systems Pvt Ltd
Name of contact person	Narendra Vadher
Address of company	Plot No: 1517; Phase III; GIDC, Vatva, Ahmedabad
Contact no & Fax no	079-5834987,5890158 &079-5834987
Contact email ids	vadher@ad1.vsnl.net.in
Company website	www.aerothermsystem.com

Annexure 8 Quotations of energy efficient gas fired hot air generator



EMAIL MSG.: GREEN-06

18TH OCTOBER, 2010

TECHNICAL SPECIFICATION

**TWO PASS GAS FIRED FULLY AUTOMATIC
INDIRECT AIR HEATER**

MODEL	:	AHA - 300 - G
CAPACITY	:	30,000 KCAL/HR
AIR TEMP. AT OUTLET	:	150 DEG C
BLOWER HP	:	2 HP
BURNER	:	FULLY AUTOMATIC
FUEL	:	NATURAL GAS
C V OF NATURAL GAS	:	8,400 KCAL/M3
FUEL CONSUMPTION	:	4.5 M3/HR
GAS PRESSURE REQUIRED	:	50 - 80 mBAR (ADJUSTABLE)
BURNER BLOWER HP	:	1/4 HP
TOTAL CONNECTED ELECT. LOAD	:	2.25 HP
CONTROL	:	ON - OFF
ELECTRIC SUPPLY	:	AC 3 PHASE 415 V 50 HZ
NOZZLE DETAILS		
-HOT AIR OUTLET	:	9" X 9"
-FUEL GAS INLET	:	1/2" BSP
PRICE DETAIL		
-PRICE OF THE OFFERED EQUIPMENT	:	RS. 2,25,000-00 EACH UNIT.
		RS. TWO LAC TWENTY FIVE THOUSAND ONLY.

NOTE : GAS VALVE TRAIN, GAS PIPING, PRESSURE REGULATOR, ETC. WILL BE PROVIDED BY CLIENT.

: DUCT WITH INSULATION BETWEEN DRYER & HAG WILL BE PROVIDED BY YOU.

Miss Walker



EMAIL MSG.: GREEN-06

18TH OCTOBER, 2010

TYPE : AHA - G

SCOPE OF SUPPLY

FRONT PLATE & BACK PLATE : FABRICATED FROM HEAVY DUTY MS PLATE OF SUFFICIENT THICKNESS, WELDED CONSTRUCTION AND LINING WITH ACC CASTABLE REFRACTORY AT BACK SIDE.

BODY : FABRICATED FROM GOOD QUALITY MS PLATE HAVING SUFFICIENT THICKNESS AND STIFFENERS FROM OUTSIDE.

FLUE PIPES : MS ERW HEAVY DUTY PIPES, WELDED AT BOTH END HAVING AMPLE AREA OF HEAT TRANSFER, ARRANGE TO GIVE **TWO / THREE PASS** OF FLUE GAS.

FIRE CHAMBER & INSIDE FIRE WORK : FIRE CHAMBER WILL BE SHELL TYPE FABRICATED FROM GOOD QUALITY **SS 304 PLATE** OF SUFFICIENT THICKNESS AND HAVE INSIDE LINING WITH ACC FIRECRET-SUPER CASTABLE REFRACTORY TO PROTECT THE CHAMBER FROM HEAT.

ALL PARTS FROM INSIDE OF FIRE ZONE WILL ALSO LINING WITH CASTABLE REFRACTORY.

OUTSIDE INSULATION: COMPLETE UNIT WILL BE INSULATED FROM OUTSIDE BY MINERAL WOOL HAVING SUFFICIENT THICKNESS TO PROTECT THE HEAT LOSSES FROM THE SURFACE AND THEN CLADDING WITH ALUMINUM SHEET.

MOUNTING & BASE PLATE : COMPLETE UNIT WILL BE FLOOR MOUNTED TYPE, FACTORY FINISHED, MOUNTED ON STAND FABRICATED FROM MS CHANNEL SECTION WITH SUFFICIENT SUPPORTING MEMBERS.

Umas



EMAIL MSG.: GREEN-06

18TH OCTOBER, 2010

TYPE : AHA - G

SCOPE OF SUPPLY

BURNER : OUR OWN MAKE FULLY AUTOMATIC NOZZLE MIX GAS BURNER HAVING FOLLOWING MAJOR ITEMS.

- BURNER BODY WITH MOUNTING PLATE
- COMBUSTION AIR BLOWER WITH MOTOR MOUNTED ON THE BURNER BODY WILL DELIVERS THE SUFFICIENT QUANTITY OF AIR WITH PRESSURE TO OVER COME THE FLUE PASS RESISTANCE.
- SOLENOID VALVE.
- GAS NOZZLE WITH FLEXIBLE PIPES.
- S.S. DIFFUSER WITH ROD.
- IGNITION TRANSFORMER WITH SET OF ELECTRODES, H T LEADS AND SOCKET.

AIR BLOWER : MS FABRICATED HEAVY DUTY CENTRIFUGAL TYPE AIR BLOWER WILL BE PROVIDED WITH UNIT.

IMPELLER OF THE BLOWER WILL BE FABRICATED FROM MS SHEET, DULY DYNAMICALLY BALANCED, MOUNTED ON EN-8 SHAFT RUNNING ON BEARING PEDESTAL OF GREASE LUBRICATED.

CONTROL PANEL : DUST PROOF , FOOL PROOF, PRE-WIRED CONTROL PANEL CONSISTING OF FOLLOWING MAJOR ITEM

- CONTACTORS FOR BLOWER AND BURNER MOTORS
- OVER CURRENT RELAYS FOR MOTORS
- DIGITAL TEMP. INDICATOR CONTROLLER WITH THERMOCOUPLE.
- SEQUENCE CONTROLLER FOR BURNER WITH FLAME MONITOR UNIT.
- MAIN ISOLATOR SWITCH, MCBS, INDICATING LAMPS.
- ALARM HOOTER.

NOTE : DUCT WITH INSULATION BETWEEN DRYER & HAG WILL BE PROVIDED BY YOU.

Umesh Wadhwa



Bureau of Energy Efficiency (BEE)

(Ministry of Power, Government of India)

4th Floor, Sewa Bhawan, R. K. Puram, New Delhi – 110066

Ph.: +91 – 11 – 26179699 (5 Lines), Fax: +91 – 11 – 26178352

Websites: www.bee-india.nic.in, www.energymanagertraining.com



Winrock International India

788 Udyog Vihar, Phase V
Gurgaon – 122 001, Haryana

Tel: +91-124-4303868

Fax: +91-124-4303862

Website: www.winrockindia.org



India SME Technology Services Ltd

DFC Building, Plot No.37-38,

D-Block, Pankha Road,

Institutional Area, Janakpuri, New Delhi-110058

Tel: +91-11-28525534, Fax: +91-11-28525535

Website: www.techsmall.com